

ARNO®

WERKZEUGE

We have a passion for precision.

AUSFÜHRUNG AFD

Design AFD

D100 = speziell für die Graphitbearbeitung
DLC = für die Bearbeitung von NE-Metallen

D100 = especially for graphite machining
DLC = for machining of non-ferrous materials

Die hohe Härte der Beschichtung macht die ARNO® AFD Fräser besonders verschleißfest und verbessert die Standzeit. Die ultrafeine Diamantbeschichtung überzeugt durch eine optimale Oberflächengüte und hohe Leistungsfähigkeit.

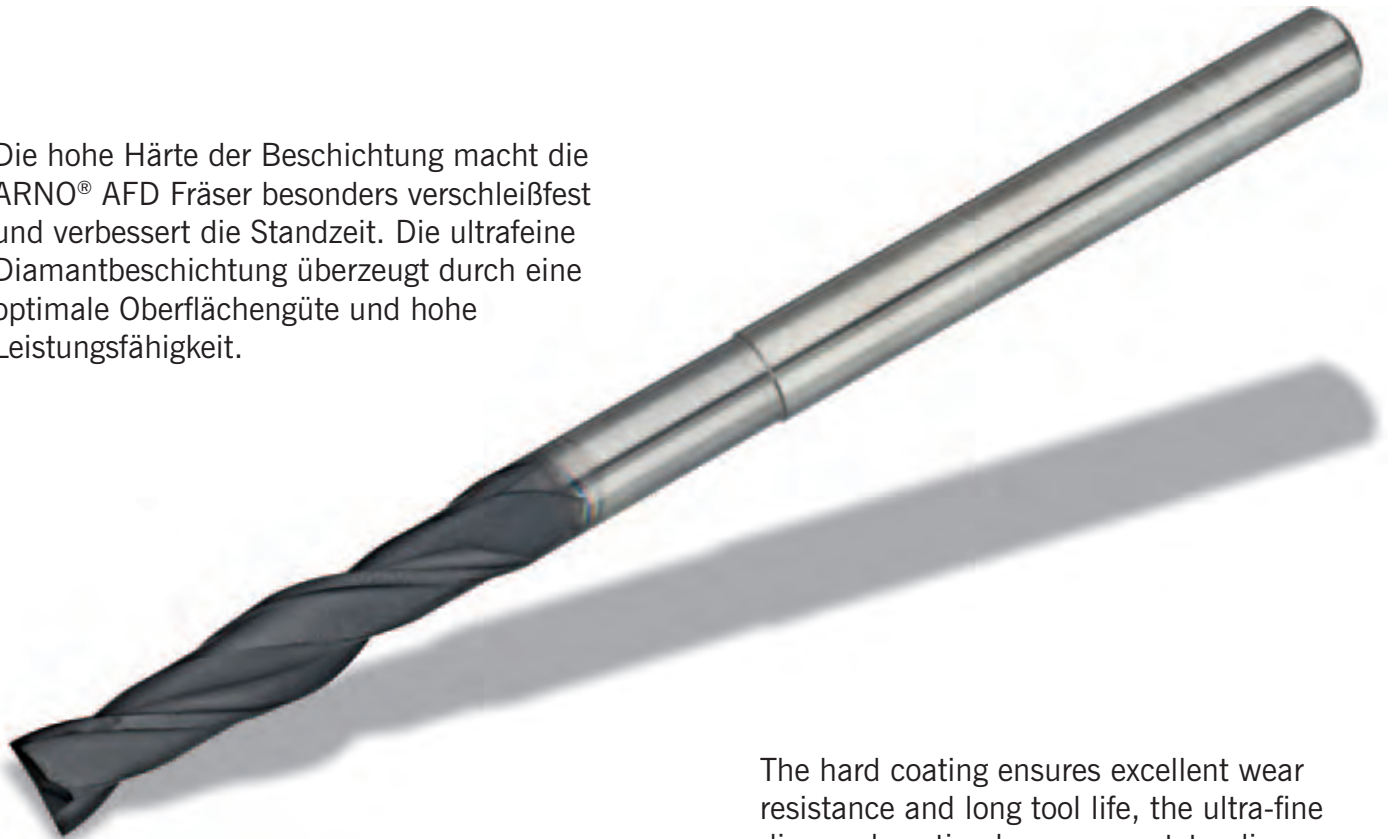

The hard coating ensures excellent wear resistance and long tool life, the ultra-fine diamond coating leaves an outstanding surface finish.

VHM-Schaftfräser

2 Schneiden Mini Ausführung mit Eckenradius

Solid carbide-End mill

2 flutes, mini design, with corner radius



AFD50724-...R...

Schaft / Shank DIN 6535HA	d	d _A	d ₃	l ₁	l ₂	l	R
AFD50724-002A	0,2	3	-	0,3	-	40	-
AFD50724-003A	0,3	3	-	0,5	-	40	-
AFD50724-004A	0,4	3	-	0,6	-	40	-
AFD50724-005AR0,05	0,5	3	0,45	0,7	2,5	40	0,05
AFD50724-005BR0,05	0,5	3	0,45	0,7	4	40	0,05
AFD50724-006AR0,05	0,6	3	0,55	0,9	3	40	0,05
AFD50724-006BR0,05	0,6	3	0,55	0,9	5	40	0,05
AFD50724-008AR0,05	0,8	3	0,75	1,2	4	40	0,05
AFD50724-008BR0,05	0,8	3	0,75	1,2	7	40	0,05
AFD50724-010AR0,1	1,0	3	0,95	1,5	5	40	0,1
AFD50724-010BR0,1	1,0	3	0,95	1,5	8,5	40	0,1
AFD50724-010CR0,1	1,0	3	0,95	1,5	12	40	0,1
AFD50724-012AR0,1	1,2	3	1,15	1,8	6	50	0,1
AFD50724-012BR0,1	1,2	3	1,15	1,8	10	50	0,1
AFD50724-015AR0,15	1,5	3	1,4	2,2	7,5	50	0,15
AFD50724-015BR0,15	1,5	3	1,4	2,2	12	50	0,15
AFD50724-015CR0,15	1,5	3	1,4	2,2	18	50	0,15
AFD50724-020AR0,15	2,0	3	1,9	2,2	10	60	0,15
AFD50724-020BR0,15	2,0	3	1,9	2,2	16	60	0,15
AFD50724-020CR0,15	2,0	3	1,9	2,2	25	60	0,15
AFD50724-030AR0,2	3,0	4	2,9	3,0	10	65	0,2
AFD50724-030BR0,2	3,0	4	2,9	3,0	15	65	0,2
AFD50724-030CR0,2	3,0	4	2,9	3,0	20	65	0,2
AFD50724-030DR0,2	3,0	4	2,9	3,0	25	75	0,2
AFD50724-030ER0,2	3,0	4	2,9	3,0	30	75	0,2
AFD50724-040AR0,2	4,0	6	3,9	4,0	20	65	0,2
AFD50724-040BR0,2	4,0	6	3,9	4,0	30	75	0,2
AFD50724-040CR0,2	4,0	6	3,9	4,0	40	90	0,2
AFD50724-050AR0,3	5,0	6	4,9	5,0	20	75	0,3
AFD50724-050BR0,3	5,0	6	4,9	5,0	30	75	0,3
AFD50724-050CR0,3	5,0	6	4,9	5,0	40	90	0,3
AFD50724-050DR0,3	5,0	6	4,9	5,0	50	90	0,3
AFD50724-060AR0,3	6,0	6	5,9	6,0	30	75	0,3
AFD50724-060BR0,3	6,0	6	5,9	6,0	40	90	0,3
AFD50724-060CR0,3	6,0	6	5,9	6,0	50	90	0,3
AFD50724-060DR0,3	6,0	6	5,9	6,0	60	100	0,3

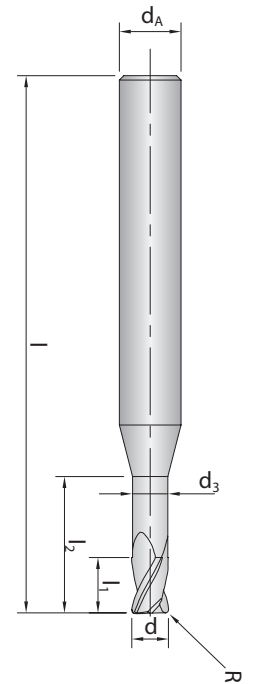

Toleranz / Tolerance	
Fräser / Mill	0 -0,02
Schaft / Shank	h6

D100 = speziell für die Graphitbearbeitung
DLC = für die Bearbeitung von NE-Metallen

D100 = especially for graphite machining
DLC = for machining of non-ferrous materials

Lieferbar ab Quartal 2/2012
Available from quarter 2/2012

● = Hauptanwendung / Main application
○ = Nebenanwendung / Suitable

Alle Angaben in mm / Dimensions in mm

VHM-Schaftfräser (Schlitzfräsen)

2 Schneiden, mit Eckenradius und konischem Schaftteil



Solid carbide-End mill (Slotting)

2 flutes, with corner radius and taper neck

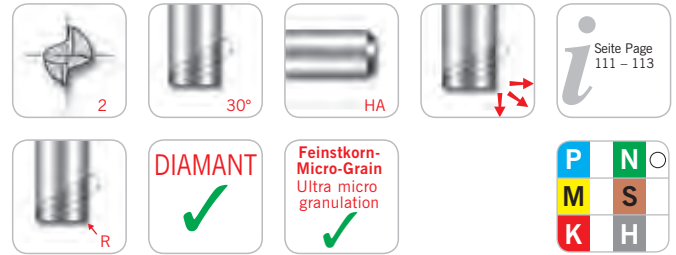

AFD50727-...R...

Schaft / Shank DIN 6535HA	d	d _A	l ₁	l ₂	l	R	A
AFD50727-010AR0,1	1,0	3	2	30	60	0,10	2°
AFD50727-010BR0,1	1,0	3	2	70	100	0,10	1°
AFD50727-015AR0,15	1,5	3	3	30	60	0,15	1°30'
AFD50727-015BR0,15	1,5	3	3	50	100	0,15	1°
AFD50727-020AR0,15	2,0	3	4	30	60	0,15	1°
AFD50727-020BR0,15	2,0	4	4	70	100	0,15	1°

Toleranz / Tolerance	
Fräser / Mill	0
Schaft / Shank	h6

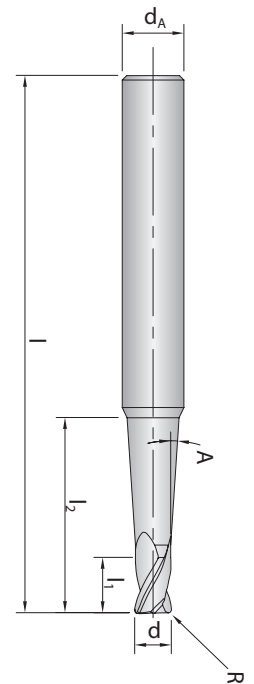

D100 = speziell für die Graphitbearbeitung
DLC = für die Bearbeitung von NE-Metallen

D100 = especially for graphite machining
DLC = for machining of non-ferrous materials

Lieferbar ab Quartal 2/2012
Available from quarter 2/2012

● = Hauptanwendung / Main application
○ = Nebenanwendung / Suitable

Alle Angaben in mm / Dimensions in mm

VHM-Schaftfräser

2 Schneiden, lange Ausführung

Solid carbide-End mill

2 flutes, long design

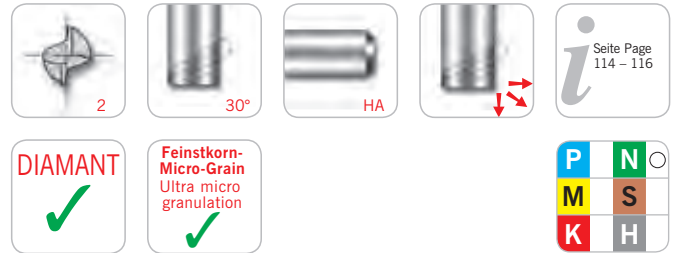

Seite Page
114 - 116



AFD50121-...

Schaft / Shank DIN 6535HA	d	d _A	d ₃	l ₁	l ₂	l
AFD50121-005	0,5	3	0,45	1,0	2	40
AFD50121-006	0,6	3	0,55	2,0	3	40
AFD50121-007	0,7	3	0,65	2,0	4	40
AFD50121-008	0,8	3	0,75	2,0	5	40
AFD50121-009	0,9	3	0,85	2,0	6	40
AFD50121-010	1,0	4	0,95	3,0	8	75
AFD50121-015	1,5	4	1,45	4,0	10	75
AFD50121-020	2,0	4	1,90	6,0	16	100
AFD50121-025	2,5	4	2,40	8,0	20	100
AFD50121-030	3,0	6	2,80	8,0	30	100
AFD50121-035	3,5	6	3,20	10,0	35	100
AFD50121-040	4,0	6	3,70	20,0	40	100
AFD50121-050	5,0	6	4,60	25,0	50	125
AFD50121-060	6,0	6	5,60	30,0	60	140
AFD50121-070	7,0	6	-	35,0	-	140
AFD50121-080	8,0	8	7,40	40,0	80	150
AFD50121-090	9,0	8	-	45,0	-	150
AFD50121-100	10,0	10	9,40	50,0	80	150
AFD50121-110	11,0	10	-	50,0	-	150
AFD50121-120	12,0	12	11,40	55,0	80	150

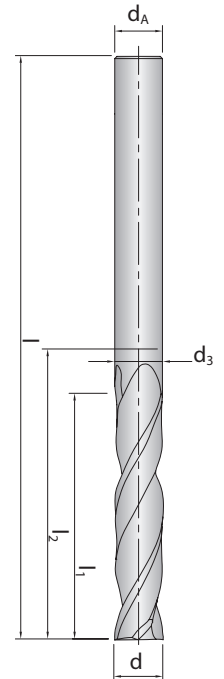

Toleranz / Tolerance	
Fräser / Mill	0
Schaft / Shank	h6

D100 = speziell für die Graphitbearbeitung
DLC = für die Bearbeitung von NE-Metallen

D100 = especially for graphite machining
DLC = for machining of non-ferrous materials

Lieferbar ab Quartal 2/2012
Available from quarter 2/2012

● = Hauptanwendung / Main application
○ = Nebenanwendung / Suitable

Alle Angaben in mm / Dimensions in mm

VHM-Schaftfräser

2 Schneiden, kurze Ausführung



Solid carbide-End mill

2 flutes, short design



AFD51520-...

Schaft / Shank DIN 6535HA	d	d _A	l ₁	l
AFD51520-010	1,0	4	3	40
AFD51520-015	1,5	4	4	40
AFD51520-020	2,0	4	6	40
AFD51520-025	2,5	4	8	40
AFD51520-030	3,0	6	8	45
AFD51520-035	3,5	6	10	45
AFD51520-040	4,0	6	11	45
AFD51520-045	4,5	6	11	50
AFD51520-050	5,0	6	13	50
AFD51520-055	5,5	6	13	50
AFD51520-060	6,0	6	13	50
AFD51520-070	7,0	8	16	60
AFD51520-080	8,0	8	19	60
AFD51520-090	9,0	10	19	70
AFD51520-100	10,0	10	22	70
AFD51520-110	11,0	12	22	75
AFD51520-120	12,0	12	26	75
AFD51520-160	16,0	16	32	90
AFD51520-200	20,0	20	38	100

Toleranz / Tolerance	
Fräser / Mill	0 -0,03
Schaft / Shank	h6

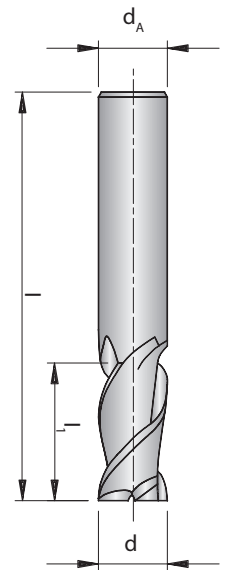

D100 = speziell für die Graphitbearbeitung
DLC = für die Bearbeitung von NE-Metallen

D100 = especially for graphite machining
DLC = for machining of non-ferrous materials

Lieferbar ab Quartal 2/2012
Available from quarter 2/2012

● = Hauptanwendung / Main application
○ = Nebenanwendung / Suitable

Alle Angaben in mm / Dimensions in mm

VHM-Radiusfräser

2 Schneiden Mini Ausführung

Solid carbide Ball-nose milling cutter

2 flutes, mini design

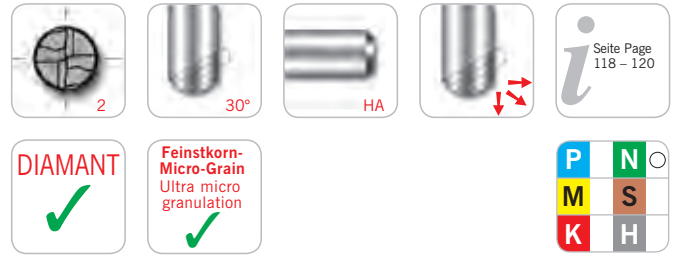

Seite Page
118 - 120

P	N	○
M	S	
K	H	

AFD

AFD51824-...

Schaft / Shank DIN 6535HA	d	d _A	d ₃	l ₁	l ₂	l	R
AFD51824-002A	0,2	3	-	0,2	-	40	0,10
AFD51824-003A	0,3	3	-	0,3	-	40	0,15
AFD51824-004A	0,4	3	-	0,4	-	40	0,20
AFD51824-005A	0,5	3	0,45	0,5	2,5	40	0,25
AFD51824-006A	0,6	3	0,55	0,6	3	40	0,30
AFD51824-006B	0,6	3	0,55	0,6	5	40	0,30
AFD51824-008A	0,8	3	0,75	0,8	4	40	0,40
AFD51824-008B	0,8	3	0,75	0,8	7	40	0,40
AFD51824-010A	1,0	3	0,95	1,0	5	40	0,50
AFD51824-010B	1,0	3	0,95	1,0	8,5	40	0,50
AFD51824-010C	1,0	3	0,95	1,0	12	40	0,50
AFD51824-012A	1,2	3	1,15	1,2	6	50	0,60
AFD51824-012B	1,2	3	1,15	1,2	10	50	0,60
AFD51824-015A	1,5	3	1,40	1,5	7,5	50	0,75
AFD51824-015B	1,5	3	1,40	1,5	12	50	0,75
AFD51824-015C	1,5	3	1,40	1,5	18	50	0,75
AFD51824-020A	2,0	3	1,90	2,2	10	60	1,00
AFD51824-020B	2,0	3	1,90	2,2	16	60	1,00
AFD51824-020C	2,0	3	1,90	2,2	25	60	1,00
AFD51824-030A	3,0	4	2,90	3,0	10	65	1,50
AFD51824-030B	3,0	4	2,90	3,0	15	65	1,50
AFD51824-030C	3,0	4	2,90	3,0	20	65	1,50
AFD51824-030D	3,0	4	2,90	3,0	25	75	1,50
AFD51824-030E	3,0	4	2,90	3,0	30	75	1,50
AFD51824-040A	4,0	6	3,90	4,0	20	65	2,00
AFD51824-040B	4,0	6	3,90	4,0	30	75	2,00
AFD51824-040C	4,0	6	3,90	4,0	40	90	2,00
AFD51824-050A	5,0	6	4,90	5,0	20	65	2,50
AFD51824-050B	5,0	6	4,90	5,0	30	75	2,50
AFD51824-050C	5,0	6	4,90	5,0	40	90	2,50
AFD51824-050D	5,0	6	4,90	5,0	50	90	2,50
AFD51824-060A	6,0	6	5,90	6,0	30	75	3,00
AFD51824-060B	6,0	6	5,90	6,0	40	90	3,00
AFD51824-060C	6,0	6	5,90	6,0	50	90	3,00
AFD51824-060D	6,0	6	5,90	6,0	60	100	3,00

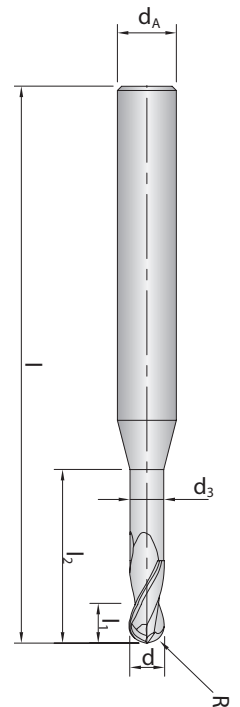

Toleranz / Tolerance	
Fräser / Mill	0
	-0,02
Radius	±0,01
Schaft / Shank	h6

D100 = speziell für die Graphitbearbeitung
DLC = für die Bearbeitung von NE-Metallen

D100 = especially for graphite machining
DLC = for machining of non-ferrous materials

Lieferbar ab Quartal 2/2012
Available from quarter 2/2012

● = Hauptanwendung / Main application
○ = Nebenanwendung / Suitable

Alle Angaben in mm / Dimensions in mm

VHM-Radiusfräser

2 Schneiden Mini Ausführung



Solid carbide Ball-nose milling cutter

2 flutes, mini design

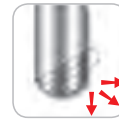

AFD50325-...

Schaft / Shank DIN 6535HA	d	d _A	d ₃	l ₁	l ₂	l	R
AFD50325-004A	0,4	4	0,36	0,6	4	45	0,2
AFD50325-004B	0,4	4	0,36	0,6	6	45	0,2
AFD50325-006A	0,6	4	0,56	1,0	4	45	0,3
AFD50325-006B	0,6	4	0,56	1,0	6	45	0,3
AFD50325-006C	0,6	4	0,56	1,0	8	45	0,3
AFD50325-010A	1,0	4	0,95	1,5	6	45	0,5
AFD50325-010B	1,0	4	0,95	1,5	8	45	0,5
AFD50325-010C	1,0	4	0,95	1,5	12	45	0,5
AFD50325-015A	1,5	4	1,45	1,75	12	45	0,75
AFD50325-020A	2,0	4	1,95	3,0	8	60	1,0
AFD50325-020B	2,0	4	1,95	3,0	12	60	1,0
AFD50325-020C	2,0	4	1,95	3,0	16	60	1,0
AFD50325-040A	4,0	4	3,90	6,0	16	60	2,0

Toleranz / Tolerance	
Fräser / Mill	0
Radius	±0,01
Schaft / Shank	h6

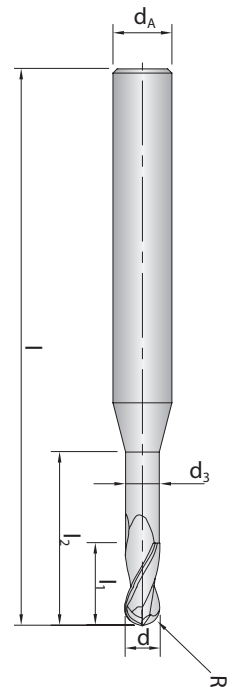

D100 = speziell für die Graphitbearbeitung
DLC = für die Bearbeitung von NE-Metallen

D100 = especially for graphite machining
DLC = for machining of non-ferrous materials

Lieferbar ab Quartal 2/2012
Available from quarter 2/2012

● = Hauptanwendung / Main application
○ = Nebenanwendung / Suitable

Alle Angaben in mm / Dimensions in mm

VHM-Radiusfräser

2 Schneiden, mit konischem Schaftteil

Solid carbide Ball-nose milling cutter

2 flutes, with taper neck

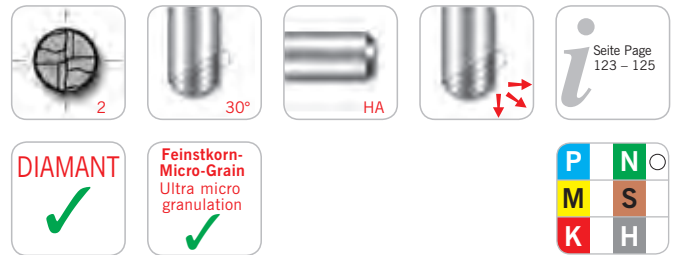

AFD

AFD51826-...

Schaft / Shank DIN 6535HA	d	d _A	l ₁	l ₂	l	R	A
AFD51826-010A	1,0	3	2	-	40	0,50	8°30'
AFD51826-010B	1,0	3	2	30	60	0,50	2°
AFD51826-010C	1,0	3	2	70	100	0,50	1°
AFD51826-015A	1,5	3	3	-	40	0,75	6°15'
AFD51826-015B	1,5	3	3	30	60	0,75	1°30'
AFD51826-015C	1,5	3	3	58	100	0,75	45°
AFD51826-020A	2,0	3	4	-	40	1,00	4°15'
AFD51826-020B	2,0	3	4	30	60	1,00	1°
AFD51826-020C	2,0	4	4	70	100	1,00	1°

Toleranz / Tolerance	
Fräser / Mill	0
Radius	±0,01
Schaft / Shank	h6

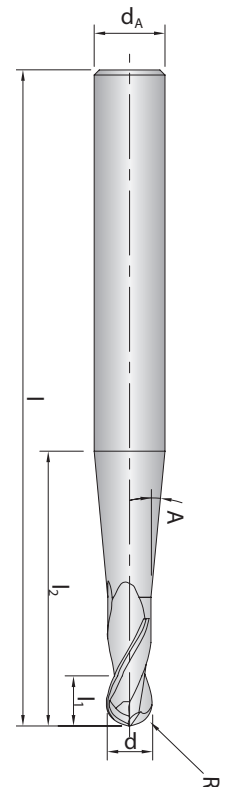

D100 = speziell für die Graphitbearbeitung
 DLC = für die Bearbeitung von NE-Metallen
 D100 = especially for graphite machining
 DLC = for machining of non-ferrous materials

Lieferbar ab Quartal 2/2012
 Available from quarter 2/2012

● = Hauptanwendung / Main application
 ○ = Nebenanwendung / Suitable

Alle Angaben in mm / Dimensions in mm

VHM-Radiusfräser

2 Schneiden, lange Ausführung



Solid carbide Ball-nose milling cutter

2 flutes, long design

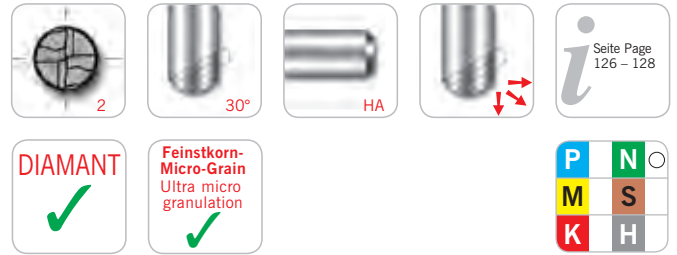

AFD51821-...

Schaft / Shank DIN 6535HA	d	d _A	d ₃	l ₁	l ₂	l	R
AFD51821-020	2,0	4	1,95	10	20	80	1,0
AFD51821-030	3,0	4	2,9	15	25	80	1,5
AFD51821-040	4,0	4	3,9	20	30	80	2,0
AFD51821-050	5,0	6	4,9	30	50	100	2,5
AFD51821-060	6,0	6	5,5	30	50	100	3,0
AFD51821-070	7,0	6	5,5	30	-	100	3,5
AFD51821-080	8,0	8	7,5	40	60	110	4,0
AFD51821-090	9,0	8	-	40	-	110	4,5
AFD51821-100	10,0	10	9,5	50	70	120	5,0
AFD51821-120	12,0	12	11,5	55	75	130	6,0

Toleranz / Tolerance	
Fräser / Mill	0
Radius	±0,01
Schaft / Shank	h6

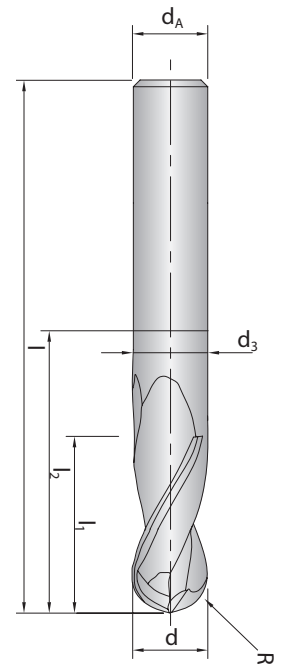

D100 = speziell für die Graphitbearbeitung
DLC = für die Bearbeitung von NE-Metallen

D100 = especially for graphite machining
DLC = for machining of non-ferrous materials

Lieferbar ab Quartal 2/2012
Available from quarter 2/2012

● = Hauptanwendung / Main application
○ = Nebenanwendung / Suitable

Alle Angaben in mm / Dimensions in mm

VHM-Radiusfräser

2 Schneiden, überlange Ausführung



Solid carbide Ball-nose milling cutter

3 flutes, extra long design

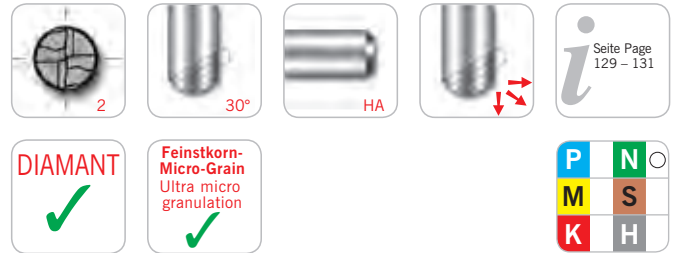

AFD

AFD51823-...

Schaft / Shank DIN 6535HA	d	d _A	d ₃	l ₁	l ₂	l	R
AFD51823-020	2,0	4	1,95	10	20	100	1,0
AFD51823-030	3,0	4	2,9	15	25	100	1,5
AFD51823-040	4,0	4	3,9	20	30	100	2,0
AFD51823-050	5,0	6	4,9	30	50	120	2,5
AFD51823-060	6,0	6	5,5	30	50	150	3,0
AFD51823-070	7,0	6	-	30	-	150	3,5
AFD51823-080	8,0	8	7,5	40	60	150	4,0
AFD51823-090	9,0	8	-	40	-	150	4,5
AFD51823-100	10,0	10	9,5	50	70	180	5,0
AFD51823-120	12,0	12	11,5	55	75	200	6,0

Toleranz / Tolerance	
Fräser / Mill	0
Radius	-0,03
Schaft / Shank	±0,01
	h6

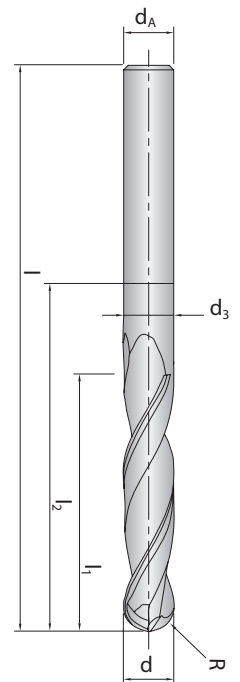

D100 = speziell für die Graphitbearbeitung
 DLC = für die Bearbeitung von NE-Metallen
 D100 = especially for graphite machining
 DLC = for machining of non-ferrous materials

Lieferbar ab Quartal 2/2012
 Available from quarter 2/2012

● = Hauptanwendung / Main application
 ○ = Nebenanwendung / Suitable

Alle Angaben in mm / Dimensions in mm

VHM-Radiusfräser

2 Schneiden, kurze Ausführung



Solid carbide Ball-nose milling cutter

2 flutes, short design

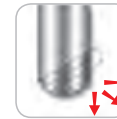

AFD51820-...

Schaft / Shank DIN 6535HA	d	d _A	d ₃	l ₁	l ₂	l	R
AFD51820-020	2,0	6	1,9	3,0	5,0	60	1,00
AFD51820-025	2,5	6	2,4	4,0	6,0	60	1,25
AFD51820-030	3,0	6	2,8	4,5	6,5	60	1,50
AFD51820-035	3,5	6	3,2	5,0	7,0	65	1,75
AFD51820-040	4,0	6	3,7	6,0	8,0	65	2,00
AFD51820-050	5,0	6	4,6	7,5	10,0	65	2,50
AFD51820-060	6,0	6	5,6	9,0	12,0	75	3,00
AFD51820-080	8,0	8	7,4	12,0	25,0	75	4,00
AFD51820-100	10,0	10	9,4	15,0	30,0	80	5,00
AFD51820-120	12,0	12	11,4	18,0	36,0	90	6,00

Toleranz / Tolerance	
Fräser / Mill	0 -0,03
Radius	±0,01
Schaft / Shank	h6

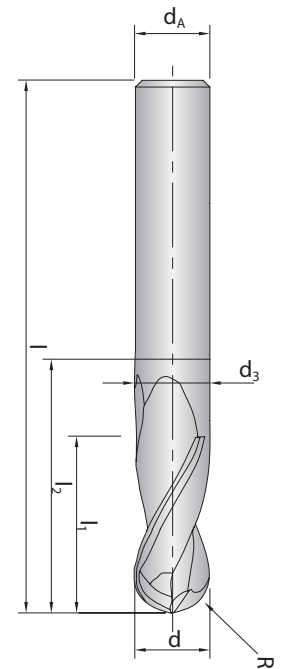

D100 = speziell für die Graphitbearbeitung
DLC = für die Bearbeitung von NE-Metallen

D100 = especially for graphite machining
DLC = for machining of non-ferrous materials

Lieferbar ab Quartal 2/2012
Available from quarter 2/2012

● = Hauptanwendung / Main application
○ = Nebenanwendung / Suitable

Alle Angaben in mm / Dimensions in mm

VHM-Schaftfräser

3 Schneiden, kurze Ausführung, mit Eckenradius



Solid carbide-End mill

3 flutes, short design, with corner radius

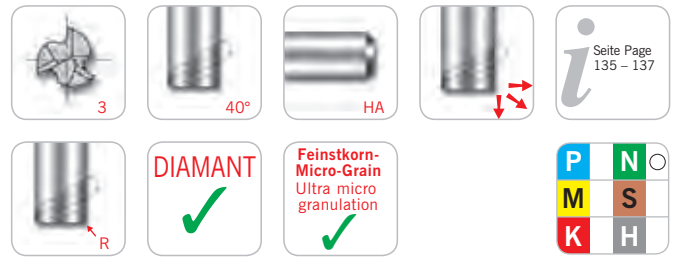

AFD54030-...R...

Schaft / Shank DIN 6535HA	d	d _A	l ₁	l	R
AFD54030-020R0,15	2,0	3	6	40	0,15
AFD54030-030R0,15	3,0	3	12	40	0,15
AFD54030-040R0,2	4,0	4	14	50	0,2
AFD54030-050R0,3	5,0	5	16	50	0,3
AFD54030-060R0,3	6,0	6	20	65	0,3
AFD54030-080R0,5	8,0	8	20	65	0,5
AFD54030-100R0,5	10,0	10	25	75	0,5
AFD54030-120R0,5	12,0	12	25	75	0,5

Toleranz / Tolerance	
Fräser / Mill	0
Schaft / Shank	h6

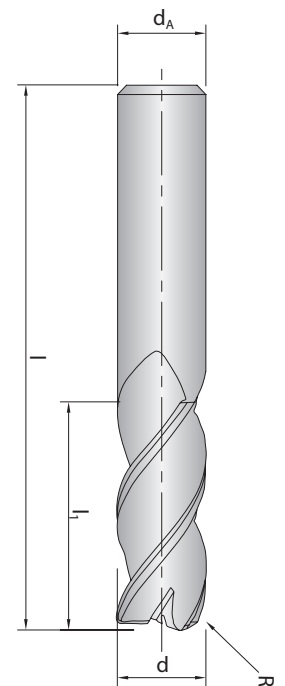

D100 = speziell für die Graphitbearbeitung
DLC = für die Bearbeitung von NE-Metallen

D100 = especially for graphite machining
DLC = for machining of non-ferrous materials

Lieferbar ab Quartal 2/2012
Available from quarter 2/2012

● = Hauptanwendung / Main application
○ = Nebenanwendung / Suitable

Alle Angaben in mm / Dimensions in mm

VHM-Schaftfräser

3 Schneiden, lange Ausführung, mit Eckenradius



Solid carbide-End mill

3 flutes, long design, with corner radius

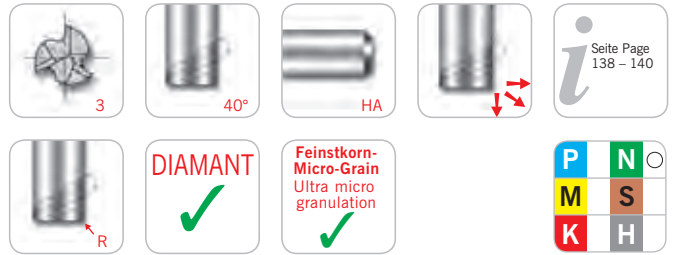

AFD54031-...R...

Schaft / Shank DIN 6535HA	d	d _A	l ₁	l	R
AFD54031-020R0,15	2,0	3	9	60	0,15
AFD54031-030R0,15	3,0	3	30	60	0,15
AFD54031-040R0,2	4,0	4	30	60	0,20
AFD54031-050R0,3	5,0	5	35	70	0,30
AFD54031-060R0,3	6,0	6	40	100	0,30
AFD54031-080R0,5	8,0	8	40	100	0,50
AFD54031-100R0,5	10,0	10	40	100	0,50
AFD54031-120R0,5	12,0	12	45	100	0,50

Toleranz / Tolerance	
Fräser / Mill	0
Schaft / Shank	h6

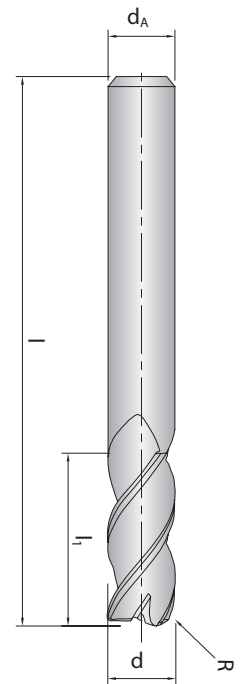

D100 = speziell für die Graphitbearbeitung
DLC = für die Bearbeitung von NE-Metallen

D100 = especially for graphite machining
DLC = for machining of non-ferrous materials

Lieferbar ab Quartal 2/2012
Available from quarter 2/2012

● = Hauptanwendung / Main application
○ = Nebenanwendung / Suitable

Alle Angaben in mm / Dimensions in mm

VHM-Radiusfräser

3 Schneiden, kurze Ausführung



Solid carbide Ball-nose milling cutter

3 flutes, short design

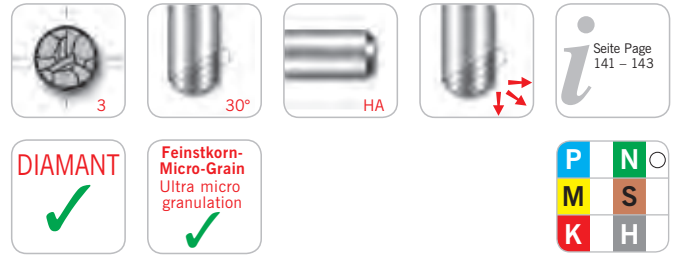

AFD51830-...

Schaft / Shank DIN 6535HA	d	d _A	d ₃	l ₁	l ₂	l	R
AFD51830-020	2,0	6	1,9	3	5	60	1,0
AFD51830-025	2,5	6	2,4	4	6	60	1,25
AFD51830-030	3,0	6	2,8	4,5	6,5	60	1,5
AFD51830-035	3,5	6	3,2	5	7	65	1,75
AFD51830-040	4,0	6	3,7	6	8	65	2,0
AFD51830-050	5,0	6	4,6	7,5	10	65	2,5
AFD51830-060	6,0	6	5,6	9	12	75	3,0
AFD51830-080	8,0	8	7,4	12	25	75	4,0
AFD51830-100	10,0	10	9,4	15	30	80	5,0
AFD51830-120	12,0	12	11,4	18	36	90	6,0

Toleranz / Tolerance	
Fräser / Mill	0
Radius	-0,03
Schaft / Shank	±0,01
	h6

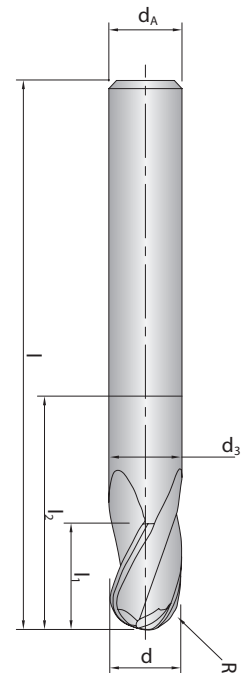

D100 = speziell für die Graphitbearbeitung
DLC = für die Bearbeitung von NE-Metallen

D100 = especially for graphite machining
DLC = for machining of non-ferrous materials

Lieferbar ab Quartal 2/2012
Available from quarter 2/2012

● = Hauptanwendung / Main application
○ = Nebenanwendung / Suitable

Alle Angaben in mm / Dimensions in mm

AFD

VHM-Schaftfräser

4 Schneiden mit Eckenradius



Solid carbide-End mill

4 flutes, with corner radius

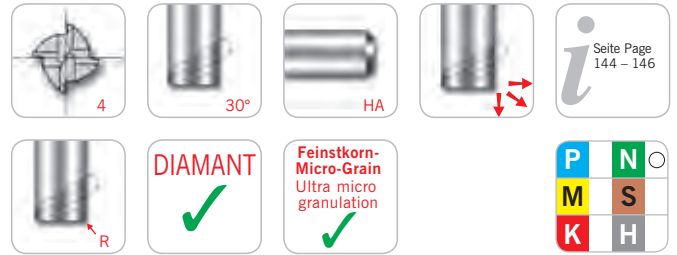

AFD50740-...R...

Schaft / Shank DIN 6535HA	d	d _A	d ₃	l ₁	l ₂	l	R
AFD50740-060AR0,5	6,0	6	5,9	10	40	80	0,5
AFD50740-080AR0,5	8,0	8	7,8	10	40	80	0,5
AFD50740-080BR1,0	8,0	8	7,8	10	60	100	1,0
AFD50740-100AR0,5	10,0	10	-	25	-	75	0,5
AFD50740-100BR0,5	10,0	10	9,8	12	40	80	0,5
AFD50740-100CR1,0	10,0	10	9,8	12	40	80	1,0
AFD50740-100DR0,5	10,0	10	9,8	12	80	125	0,5
AFD50740-120AR0,5	12,0	12	-	25	-	80	0,5
AFD50740-120BR0,5	12,0	12	11,8	15	40	80	0,5
AFD50740-120CR1,0	12,0	12	11,8	15	40	80	1,0
AFD50740-120DR1,0	12,0	12	11,8	15	80	125	1,0

Toleranz / Tolerance

Fräser / Mill	0
Schaft / Shank	-0,03
	h6

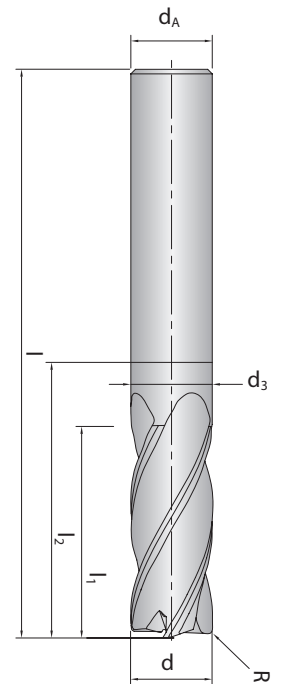

D100 = speziell für die Graphitbearbeitung
DLC = für die Bearbeitung von NE-Metallen

D100 = especially for graphite machining
DLC = for machining of non-ferrous materials

Lieferbar ab Quartal 2/2012
Available from quarter 2/2012

● = Hauptanwendung / Main application
○ = Nebenanwendung / Suitable

Alle Angaben in mm / Dimensions in mm

AFD 50724

D100-Beschichtung für Graphitbearbeitung

D100 coating for graphite machining

$\varnothing d_1$ [mm]	Z	fz [mm]	n 15000 min1 vf [mm/min.]	n 25000 min1 vf [mm/min.]	n 30000 min1 vf [mm/min.]	n 45000 min1 vf [mm/min.]
0,2	2	0,004	120	200	240	360
0,3	2	0,005	150	250	300	450
0,4	2	0,005	150	250	300	450
0,5	2	0,006	180	300	360	540
0,6	2	0,007	210	350	420	630
0,8	2	0,009	270	450	540	810
1,0	2	0,012	360	600	720	1080
1,2	2	0,015	450	750	900	1350
1,5	2	0,018	540	900	1080	1620
2,0	2	0,024	720	1200	1440	2160
3,0	2	0,035	1050	1750	2100	3150
4,0	2	0,047	1410	2350	2820	4230
5,0	2	0,059	1770	2950	3540	5310
6,0	2	0,071	2130	3550	4260	6390

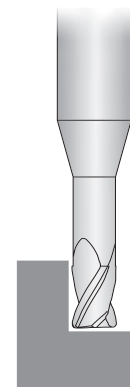

Schruppen
Roughing

$\varnothing d_1$ [mm]	Z	fz [mm]	n 15000 min1 vf [mm/min.]	n 25000 min1 vf [mm/min.]	n 30000 min1 vf [mm/min.]	n 45000 min1 vf [mm/min.]
0,2	2	0,004	120	200	240	360
0,3	2	0,004	120	200	240	360
0,4	2	0,004	120	200	240	360
0,5	2	0,005	150	250	300	450
0,6	2	0,005	150	250	300	450
0,8	2	0,007	210	350	420	630
1,0	2	0,009	270	450	540	810
1,2	2	0,011	330	550	660	990
1,5	2	0,014	420	700	840	1260
2,0	2	0,018	540	900	1080	1620
3,0	2	0,027	810	1350	1620	2430
4,0	2	0,036	1080	1800	2160	3240
5,0	2	0,045	1350	2250	2700	4050
6,0	2	0,055	1650	2750	3300	4950

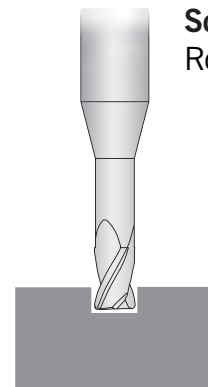

Schruppen
Roughing

Achtung:
Die angegebenen Schnittparameter sind Richt- und Startwerte.
Kundenspezifische Gegebenheiten wie Antriebsleistung, Maschinenstabilität,
Werkzeugauskragung etc. sind hierbei nicht berücksichtigt.

Attention:
These cutting data are recommendations only.
Customer specific circumstances such as machine power, stability,
tool overhang etc. are not taken into consideration.

AFD 50724

D100-Beschichtung für Graphitbearbeitung

D100 coating for graphite machining

$\varnothing d_1$ [mm]	Z	fz [mm]	n 15000 min1 vf [mm/min.]	n 25000 min1 vf [mm/min.]	n 30000 min1 vf [mm/min.]	n 45000 min1 vf [mm/min.]
0,2	2	0,004	120	200	240	360
0,3	2	0,004	120	200	240	360
0,4	2	0,005	150	250	300	450
0,5	2	0,007	210	350	420	630
0,6	2	0,008	240	400	480	720
0,8	2	0,011	330	550	660	990
1,0	2	0,013	390	650	780	1170
1,2	2	0,015	450	750	900	1350
1,5	2	0,020	600	1000	1200	1800
2,0	2	0,027	810	1350	1620	2430
3,0	2	0,040	1200	2000	2400	3600
4,0	2	0,053	1590	2650	3180	4770
5,0	2	0,067	2010	3350	4020	6030
6,0	2	0,080	2400	4000	4800	7200

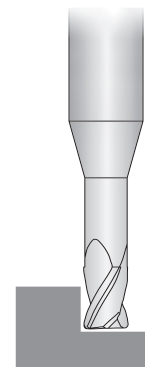
Schlichten
Finishing

AFD

$\varnothing d_1$ [mm]	Z	fz [mm]	n 15000 min1 vf [mm/min.]	n 25000 min1 vf [mm/min.]	n 30000 min1 vf [mm/min.]	n 45000 min1 vf [mm/min.]
0,2	2	0,004	120	200	240	360
0,3	2	0,004	120	200	240	360
0,4	2	0,005	150	250	300	450
0,5	2	0,007	210	350	420	630
0,6	2	0,008	240	400	480	720
0,8	2	0,011	330	550	660	990
1,0	2	0,013	390	650	780	1170
1,2	2	0,015	450	750	900	1350
1,5	2	0,020	600	1000	1200	1800
2,0	2	0,027	810	1350	1620	2430
3,0	2	0,040	1200	2000	2400	3600
4,0	2	0,053	1590	2650	3180	4770
5,0	2	0,067	2010	3350	4020	6030
6,0	2	0,080	2400	4000	4800	7200

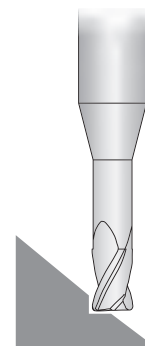
Schlichten
Finishing**Achtung:**

Die angegebenen Schnittparameter sind Richt- und Startwerte.
Kundenspezifische Gegebenheiten wie Antriebsleistung, Maschinenstabilität,
Werkzeugauskragung etc. sind hierbei nicht berücksichtigt.

Attention:

These cutting data are recommendations only.
Customer specific circumstances such as machine power, stability,
tool overhang etc. are not taken into consideration.

Alle Angaben in mm / Dimensions in mm

AFD 50724

DLC-Beschichtung für Aluminiumlegierungen

DLC coating for aluminium alloys

$\varnothing d_1$ [mm]	Z	Vc m/min.	fz [mm]	n [U/min ¹]	vf [mm/min.]
0,5	2	50	0,002	32000	130
1,0	2	100	0,003	32000	190
1,5	2	150	0,005	32000	320
2,0	2	170	0,007	27000	380
3,0	2	190	0,016	20000	640
4,0	2	190	0,022	15000	660
5,0	2	190	0,029	12000	700
6,0	2	190	0,039	10000	780

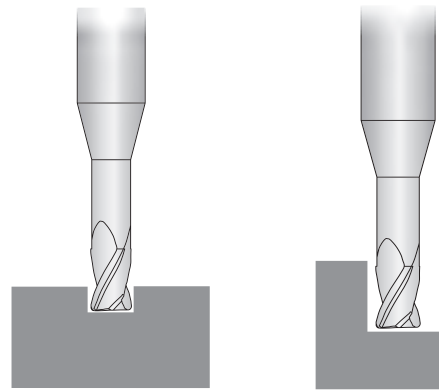

DLC-Beschichtung für Kupferlegierungen

DLC coating for copper alloys

$\varnothing d_1$ [mm]	Z	Vc m/min.	fz [mm]	n [U/min ¹]	vf [mm/min.]
0,5	2	50	0,002	32000	130
1,0	2	75	0,003	25000	150
1,5	2	75	0,005	16000	160
2,0	2	75	0,007	12000	170
3,0	2	80	0,012	8500	210
4,0	2	80	0,025	6400	320
5,0	2	80	0,033	5100	340
6,0	2	80	0,040	4300	350

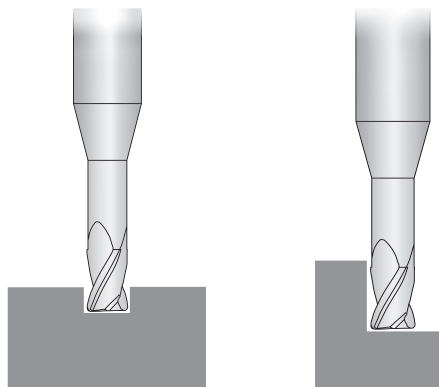

Achtung:
Die angegebenen Schnittparameter sind Richt- und Startwerte.
Kundenspezifische Gegebenheiten wie Antriebsleistung, Maschinenstabilität,
Werkzeugauskragung etc. sind hierbei nicht berücksichtigt.

Attention:
These cutting data are recommendations only.
Customer specific circumstances such as machine power, stability,
tool overhang etc. are not taken into consideration.

Alle Angaben in mm / Dimensions in mm

AFD 50727

D100-Beschichtung für Graphitbearbeitung

D100 coating for graphite machining

$\varnothing d_1$ [mm]	Z	fz [mm]	n 15000 min1 vf [mm/min.]	n 25000 min1 vf [mm/min.]	n 30000 min1 vf [mm/min.]	n 45000 min1 vf [mm/min.]
1,0	2	0,012	360	600	720	1080
1,5	2	0,018	540	900	1080	1620
2,0	2	0,024	720	1200	1440	2160

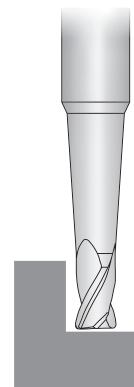

Schruppen
Roughing

AFD

$\varnothing d_1$ [mm]	Z	fz [mm]	n 15000 min1 vf [mm/min.]	n 25000 min1 vf [mm/min.]	n 30000 min1 vf [mm/min.]	n 45000 min1 vf [mm/min.]
1,0	2	0,009	270	450	540	810
1,5	2	0,014	420	700	840	1260
2,0	2	0,018	540	900	1082	1620

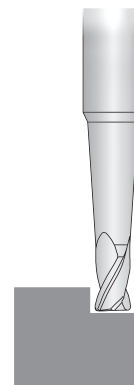

Schruppen
Roughing

Achtung:

Die angegebenen Schnittparameter sind Richt- und Startwerte.
Kundenspezifische Gegebenheiten wie Antriebsleistung, Maschinenstabilität,
Werkzeugauskragung etc. sind hierbei nicht berücksichtigt.

Attention:

These cutting data are recommendations only.
Customer specific circumstances such as machine power, stability,
tool overhang etc. are not taken into consideration.

Alle Angaben in mm / Dimensions in mm

AFD 50727**D100-Beschichtung für Graphitbearbeitung**

D100 coating for graphite machining

$\varnothing d_1$ [mm]	Z	fz [mm]	n 15000 min1 vf [mm/min.]	n 25000 min1 vf [mm/min.]	n 30000 min1 vf [mm/min.]	n 45000 min1 vf [mm/min.]
1,0	2	0,013	390	650	780	1170
1,5	2	0,020	600	1000	1200	1800
2,0	2	0,027	810	1350	1620	2430

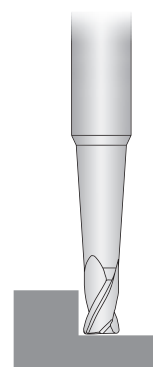
**Schlichten
Finishing**

$\varnothing d_1$ [mm]	Z	fz [mm]	n 15000 min1 vf [mm/min.]	n 25000 min1 vf [mm/min.]	n 30000 min1 vf [mm/min.]	n 45000 min1 vf [mm/min.]
1,0	2	0,013	390	650	780	1170
1,5	2	0,020	600	1000	1200	1800
2,0	2	0,027	810	1350	1620	2430

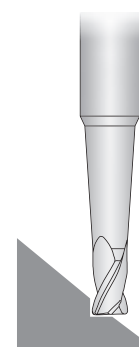
**Schlichten
Finishing**

Achtung:
Die angegebenen Schnittparameter sind Richt- und Startwerte.
Kundenspezifische Gegebenheiten wie Antriebsleistung, Maschinenstabilität,
Werkzeugauskrantung etc. sind hierbei nicht berücksichtigt.

Attention:
These cutting data are recommendations only.
Customer specific circumstances such as machine power, stability,
tool overhang etc. are not taken into consideration.

Alle Angaben in mm / Dimensions in mm

AFD 50727

DLC-Beschichtung für Aluminiumlegierungen

DLC coating for aluminium alloys

$\varnothing d_1$ [mm]	Z	Vc m/min.	fz [mm]	n [U/min ¹]	vf [mm/min.]
1,0	2	100	0,004	32000	250
1,5	2	150	0,005	32000	320
2,0	2	170	0,007	27000	380

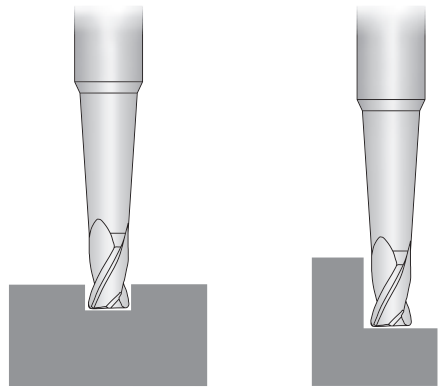

AFD

DLC-Beschichtung für Kupferlegierungen

DLC coating for copper alloys

$\varnothing d_1$ [mm]	Z	Vc m/min.	fz [mm]	n [U/min ¹]	vf [mm/min.]
1,0	2	78	0,004	25000	180
1,5	2	75	0,006	16000	190
2,0	2	75	0,008	12000	200

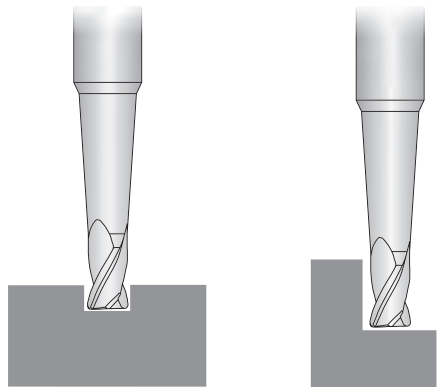
**Achtung:**

Die angegebenen Schnittparameter sind Richt- und Startwerte.
Kundenspezifische Gegebenheiten wie Antriebsleistung, Maschinenstabilität,
Werkzeugauskragung etc. sind hierbei nicht berücksichtigt.

Attention:

These cutting data are recommendations only.
Customer specific circumstances such as machine power, stability,
tool overhang etc. are not taken into consideration.

Alle Angaben in mm / Dimensions in mm

AFD 50121

D100-Beschichtung für Graphitbearbeitung

D100 coating for graphite machining

$\varnothing d_1$ [mm]	Z	fz [mm]	n 15000 min1 vf [mm/min.]	n 25000 min1 vf [mm/min.]	n 30000 min1 vf [mm/min.]	n 45000 min1 vf [mm/min.]
0,5	2	0,005	150	250	300	450
0,6	2	0,006	180	300	360	540
0,7	2	0,007	210	350	420	630
0,8	2	0,008	240	400	480	720
0,9	2	0,008	240	400	480	720
1,0	2	0,009	270	450	540	810
1,5	2	0,014	420	700	840	1260
2,0	2	0,019	570	950	1140	1710
2,5	2	0,024	720	1200	1440	2160
3,0	2	0,029	840	1400	1680	2520
3,5	2	0,032	960	1600	1920	2880
4,0	2	0,040	1200	2000	2400	3600
5,0	2	0,045	1350	2250	2700	4050
6,0	2	0,050	1500	2500	3000	4500
7,0	2	0,055	1650	2750	3300	4950
8,0	2	0,060	1800	3000	3600	5400
9,0	2	0,065	1950	3250	3900	5850
10,0	2	0,070	2100	3500	4200	6300
11,0	2	0,075	2250	3750	4500	6750
12,0	2	0,080	2400	4000	4800	7200

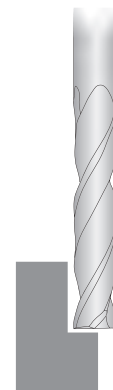
Schruppen
Roughing

$\varnothing d_1$ [mm]	Z	fz [mm]	n 15000 min1 vf [mm/min.]	n 25000 min1 vf [mm/min.]	n 30000 min1 vf [mm/min.]	n 45000 min1 vf [mm/min.]
0,5	2	0,003	90	150	180	270
0,6	2	0,003	90	150	180	270
0,7	2	0,003	90	150	180	270
0,8	2	0,004	120	200	240	360
0,9	2	0,005	150	250	300	450
1,0	2	0,005	150	250	300	450
1,5	2	0,008	240	400	480	720
2,0	2	0,011	330	550	660	990
2,5	2	0,014	420	700	840	1260
3,0	2	0,016	480	800	960	1440
3,5	2	0,019	570	950	1140	1710
4,0	2	0,021	630	1050	1260	1890
5,0	2	0,026	780	1300	1560	2340
6,0	2	0,031	930	1550	1860	2790
7,0	2	0,036	1080	1800	2160	3240
8,0	2	0,040	1200	2000	2400	3600
9,0	2	0,045	1350	2250	2700	4050
10,0	2	0,050	1500	2500	3000	4500
11,0	2	0,055	1650	2750	3300	4950
12,0	2	0,060	1800	3000	3600	5400

Schruppen
Roughing

Achtung:
Die angegebenen Schnittparameter sind Richt- und Startwerte.
Kundenspezifische Gegebenheiten wie Antriebsleistung, Maschinenstabilität,
Werkzeugauskragung etc. sind hierbei nicht berücksichtigt.

Attention:
These cutting data are recommendations only.
Customer specific circumstances such as machine power, stability,
tool overhang etc. are not taken into consideration.

Alle Angaben in mm / Dimensions in mm

AFD 50121

D100-Beschichtung für Graphitbearbeitung

D100 coating for graphite machining

$\varnothing d_1$ [mm]	Z	fz [mm]	n 15000 min1 vf [mm/min.]	n 25000 min1 vf [mm/min.]	n 30000 min1 vf [mm/min.]	n 45000 min1 vf [mm/min.]
0,5	2	0,005	150	250	300	450
0,6	2	0,006	180	300	360	540
0,7	2	0,007	210	350	420	630
0,8	2	0,009	270	450	540	810
0,9	2	0,009	270	450	540	810
1,0	2	0,011	330	550	660	990
1,5	2	0,016	480	800	960	1440
2,0	2	0,021	630	1050	1260	1890
2,5	2	0,026	780	1300	1560	2340
3,0	2	0,031	930	1550	1860	2790
3,5	2	0,036	1080	1800	2160	3240
4,0	2	0,040	1200	2000	2400	3600
5,0	2	0,045	1350	2250	2700	4050
6,0	2	0,050	1500	2500	3000	4500
7,0	2	0,055	1650	2750	3300	4950
8,0	2	0,060	1800	3000	3600	5400
9,0	2	0,065	1950	3250	3900	5850
10,0	2	0,070	2100	3500	4200	6300
11,0	2	0,075	2250	3750	4500	6750
12,0	2	0,080	2400	4000	4800	7200

Schlichten
Finishing

AFD

$\varnothing d_1$ [mm]	Z	fz [mm]	n 15000 min1 vf [mm/min.]	n 25000 min1 vf [mm/min.]	n 30000 min1 vf [mm/min.]	n 45000 min1 vf [mm/min.]
0,5	2	0,005	150	250	300	450
0,6	2	0,006	180	300	360	540
0,7	2	0,007	210	350	420	630
0,8	2	0,009	270	450	540	810
0,9	2	0,009	270	450	540	810
1,0	2	0,011	330	550	660	990
1,5	2	0,016	480	800	960	1440
2,0	2	0,021	630	1050	1260	1890
2,5	2	0,026	780	1300	1560	2340
3,0	2	0,031	930	1550	1860	2790
3,5	2	0,036	1080	1800	2160	3240
4,0	2	0,040	1200	2000	2400	3600
5,0	2	0,045	1350	2250	2700	4050
6,0	2	0,050	1500	2500	3000	4500
7,0	2	0,055	1650	2750	3300	4950
8,0	2	0,060	1800	3000	3600	5400
9,0	2	0,065	1950	3250	3900	5850
10,0	2	0,070	2100	3500	4200	6300
11,0	2	0,075	2250	3750	4500	6750
12,0	2	0,080	2400	4000	4800	7200

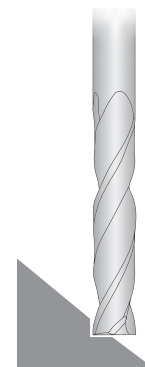
Schlichten
Finishing**Achtung:**

Die angegebenen Schnittparameter sind Richt- und Startwerte.
Kundenspezifische Gegebenheiten wie Antriebsleistung, Maschinenstabilität,
Werkzeugauskragung etc. sind hierbei nicht berücksichtigt.

Attention:

These cutting data are recommendations only.
Customer specific circumstances such as machine power, stability,
tool overhang etc. are not taken into consideration.

Alle Angaben in mm / Dimensions in mm

AFD 50121

DLC-Beschichtung für Aluminiumlegierungen

DLC coating for aluminium alloys

$\varnothing d_1$ [mm]	Z	Vc m/min.	fz [mm]	n [U/min ¹]	vf [mm/min.]
0,5	2	50	0,0015	32000	100
1,0	2	100	0,0015	32000	100
1,5	2	130	0,002	32000	200
2,0	2	170	0,005	27000	300
2,5	2	190	0,007	23000	330
3,0	2	190	0,012	20000	510
3,5	2	190	0,015	17000	510
4,0	2	190	0,017	15000	520
5,0	2	190	0,022	12000	540
6,0	2	190	0,030	10000	600
7,0	2	190	0,035	9000	630
8,0	2	200	0,040	8000	650
9,0	2	200	0,045	7200	650
10,0	2	200	0,050	6400	680
11,0	2	200	0,060	6000	720
12,0	2	200	0,070	5500	800

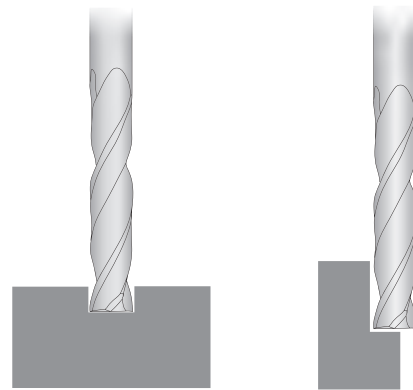

DLC-Beschichtung für Kupferlegierungen

DLC coating for copper alloys

$\varnothing d_1$ [mm]	Z	Vc m/min.	fz [mm]	n [U/min ¹]	vf [mm/min.]
0,5	2	50	0,0015	32000	100
1,0	2	75	0,003	24000	150
1,5	2	75	0,004	18000	150
2,0	2	75	0,006	12000	150
2,5	2	75	0,010	10000	200
3,0	2	75	0,014	8000	230
3,5	2	75	0,017	7000	240
4,0	2	75	0,020	6000	240
5,0	2	75	0,025	4800	240
6,0	2	80	0,030	4000	240
7,0	2	80	0,035	3500	250
8,0	2	80	0,045	3000	270
9,0	2	80	0,055	2750	300
10,0	2	80	0,065	2500	325
11,0	2	80	0,080	2250	360
12,0	2	80	0,090	2000	360

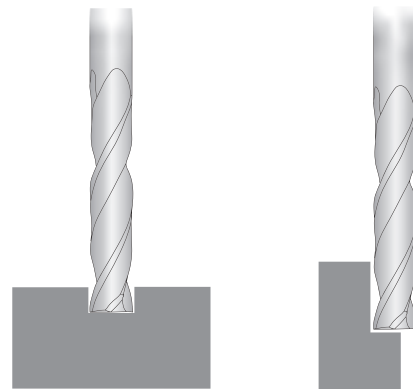

Achtung:
Die angegebenen Schnittparameter sind Richt- und Startwerte.
Kundenspezifische Gegebenheiten wie Antriebsleistung, Maschinenstabilität,
Werkzeugauskragung etc. sind hierbei nicht berücksichtigt.

Attention:
These cutting data are recommendations only.
Customer specific circumstances such as machine power, stability,
tool overhang etc. are not taken into consideration.

Alle Angaben in mm / Dimensions in mm

AFD 51520

DLC-Beschichtung für Aluminiumlegierungen

DLC coating for aluminium alloys

$\varnothing d_1$ [mm]	Z	Vc m/min.	fz [mm]	n [U/min ¹]	vf [mm/min.]
1,0	2	95	0,004	30000	260
2,0	2	190	0,007	30000	450
3,0	2	225	0,014	24000	700
4,0	2	190	0,023	20000	950
5,0	2	205	0,040	13000	1100
6,0	2	245	0,046	13000	1200
8,0	2	275	0,068	11000	1500
10,0	2	265	0,100	8500	1800
12,0	2	270	0,150	7200	2200
16,0	2	300	0,160	6000	2000
20,0	2	226	0,220	3600	1600

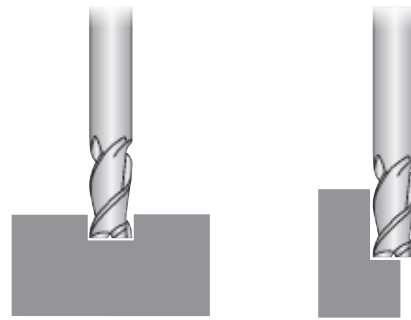

AFD

DLC-Beschichtung für Kupferlegierungen

DLC coating for copper alloys

$\varnothing d_1$ [mm]	Z	Vc m/min.	fz [mm]	n [U/min ¹]	vf [mm/min.]
1,0	2	62	0,002	20000	80
2,0	2	125	0,004	20000	160
3,0	2	130	0,010	14000	280
4,0	2	140	0,017	11000	380
5,0	2	120	0,026	7500	400
6,0	2	140	0,030	7500	480
8,0	2	150	0,050	6000	580
10,0	2	150	0,070	4800	700
12,0	2	150	0,100	3900	850
16,0	2	166	0,120	3300	780
20,0	2	125	0,150	2000	630

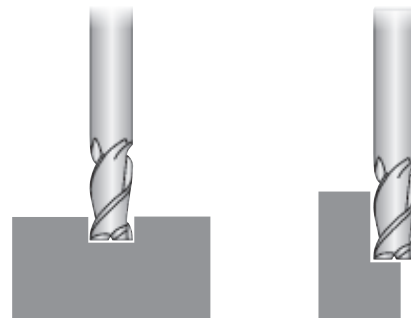
**Achtung:**

Die angegebenen Schnittparameter sind Richt- und Startwerte.
Kundenspezifische Gegebenheiten wie Antriebsleistung, Maschinenstabilität,
Werkzeugauskragung etc. sind hierbei nicht berücksichtigt.

Attention:

These cutting data are recommendations only.
Customer specific circumstances such as machine power, stability,
tool overhang etc. are not taken into consideration.

Alle Angaben in mm / Dimensions in mm

AFD 51824

D100-Beschichtung für Graphitbearbeitung

D100 coating for graphite machining

$\varnothing d_1$ [mm]	Z	fz [mm]	n 15000 min1 vf [mm/min.]	n 25000 min1 vf [mm/min.]	n 30000 min1 vf [mm/min.]	n 45000 min1 vf [mm/min.]
0,2	2	0,003	90	150	180	270
0,3	2	0,004	120	200	240	360
0,4	2	0,004	120	200	240	360
0,5	2	0,005	150	250	300	450
0,6	2	0,006	180	300	360	540
0,8	2	0,008	240	400	480	720
1,0	2	0,009	270	450	540	810
1,2	2	0,011	330	550	660	990
1,5	2	0,014	420	700	840	1260
2,0	2	0,019	570	950	1140	1710
3,0	2	0,028	840	1400	1680	2520
4,0	2	0,037	1110	1850	2220	3330
5,0	2	0,046	1380	2300	2760	4140
6,0	2	0,055	1650	2750	3300	4950

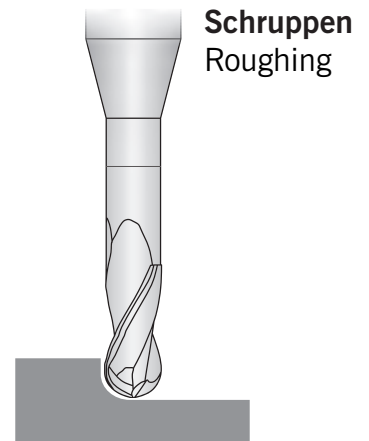

$\varnothing d_1$ [mm]	Z	fz [mm]	n 15000 min1 vf [mm/min.]	n 25000 min1 vf [mm/min.]	n 30000 min1 vf [mm/min.]	n 45000 min1 vf [mm/min.]
0,2	2	0,003	90	150	180	270
0,3	2	0,003	90	150	180	270
0,4	2	0,004	120	200	240	360
0,5	2	0,004	120	200	240	360
0,6	2	0,004	120	200	240	360
0,8	2	0,006	180	300	360	540
1,0	2	0,007	210	350	420	630
1,2	2	0,009	270	450	540	810
1,5	2	0,011	330	550	660	990
2,0	2	0,015	450	750	900	1350
3,0	2	0,022	660	1100	1320	1980
4,0	2	0,029	870	1450	1740	2610
5,0	2	0,036	1080	1800	2160	3240
6,0	2	0,043	1290	2150	2580	3870

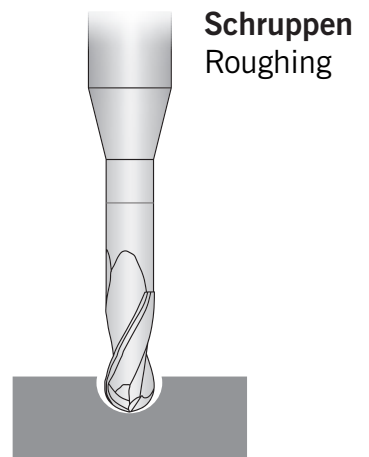

Achtung:
Die angegebenen Schnittparameter sind Richt- und Startwerte.
Kundenspezifische Gegebenheiten wie Antriebsleistung, Maschinenstabilität,
Werkzeugauskrantung etc. sind hierbei nicht berücksichtigt.

Attention:
These cutting data are recommendations only.
Customer specific circumstances such as machine power, stability,
tool overhang etc. are not taken into consideration.

Alle Angaben in mm / Dimensions in mm

AFD 51824

D100-Beschichtung für Graphitbearbeitung

D100 coating for graphite machining

$\varnothing d_1$ [mm]	Z	fz [mm]	n 15000 min1 vf [mm/min.]	n 25000 min1 vf [mm/min.]	n 30000 min1 vf [mm/min.]	n 45000 min1 vf [mm/min.]
0,2	2	0,003	90	150	180	270
0,3	2	0,004	120	200	240	360
0,4	2	0,004	120	200	240	360
0,5	2	0,005	150	250	300	450
0,6	2	0,006	180	300	360	540
0,8	2	0,009	270	450	540	810
1,0	2	0,011	330	550	660	990
1,2	2	0,013	390	650	780	1170
1,5	2	0,016	480	800	960	1440
2,0	2	0,021	630	1050	1260	1890
3,0	2	0,032	960	1600	1920	2880
4,0	2	0,042	1260	2100	2520	3780
5,0	2	0,053	1590	2650	3180	4770
6,0	2	0,063	1890	3150	3780	5670

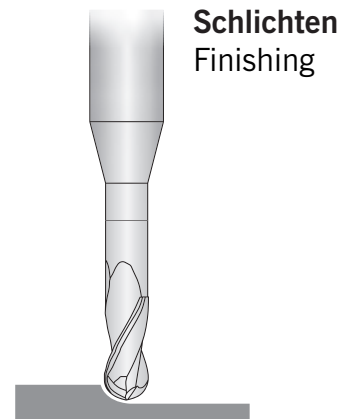

AFD

$\varnothing d_1$ [mm]	Z	fz [mm]	n 15000 min1 vf [mm/min.]	n 25000 min1 vf [mm/min.]	n 30000 min1 vf [mm/min.]	n 45000 min1 vf [mm/min.]
0,2	2	0,003	90	150	180	270
0,3	2	0,004	120	200	240	360
0,4	2	0,004	120	200	240	360
0,5	2	0,005	150	250	300	450
0,6	2	0,006	180	300	360	540
0,8	2	0,009	270	450	540	810
1,0	2	0,011	330	550	660	990
1,2	2	0,013	390	650	780	1170
1,5	2	0,016	480	800	960	1440
2,0	2	0,021	630	1050	1260	1890
3,0	2	0,032	960	1600	1920	2880
4,0	2	0,042	1260	2100	2520	3780
5,0	2	0,053	1590	2650	3180	4770
6,0	2	0,063	1890	3150	3780	5670

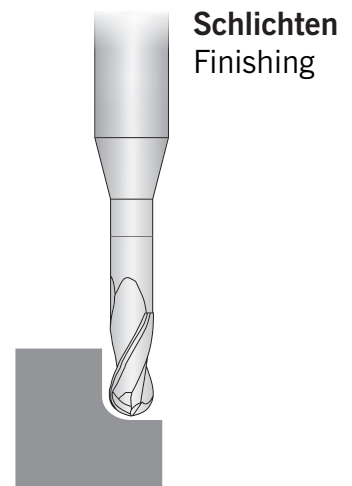
**Achtung:**

Die angegebenen Schnittparameter sind Richt- und Startwerte.
Kundenspezifische Gegebenheiten wie Antriebsleistung, Maschinenstabilität,
Werkzeugauskragung etc. sind hierbei nicht berücksichtigt.

Attention:

These cutting data are recommendations only.
Customer specific circumstances such as machine power, stability,
tool overhang etc. are not taken into consideration.

Alle Angaben in mm / Dimensions in mm

AFD 51824

DLC-Beschichtung für Aluminiumlegierungen

DLC coating for aluminium alloys

$\varnothing d_1$ [mm]	Z	Vc m/min.	fz [mm]	n [U/min ¹]	vf [mm/min.]
0,5	2	78	0,008	50000	850
0,6	2	94	0,013	50000	1300
0,8	2	125	0,016	50000	1600
1,0	2	144	0,021	46000	2000
1,2	2	146	0,025	39000	2000
1,5	2	170	0,027	36000	2000
2,0	2	170	0,030	27000	1800
3,0	2	190	0,045	20000	1800
4,0	2	190	0,060	15000	1800
5,0	2	190	0,075	12000	1800
6,0	2	190	0,090	10000	1800

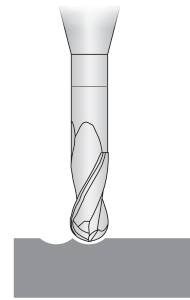

DLC-Beschichtung für Kupferlegierungen

DLC coating for copper alloys

$\varnothing d_1$ [mm]	Z	Vc m/min.	fz [mm]	n [U/min ¹]	vf [mm/min.]
0,5	2	67	0,007	43000	650
0,6	2	80	0,011	43000	1000
0,8	2	95	0,015	38000	1200
1,0	2	105	0,020	34000	1400
1,2	2	110	0,024	29000	1400
1,5	2	125	0,026	26000	1400
2,0	2	125	0,032	20000	1300
3,0	2	125	0,048	13500	1300
4,0	2	125	0,065	10000	1300
5,0	2	125	0,080	8000	1300
6,0	2	125	0,090	6800	1300

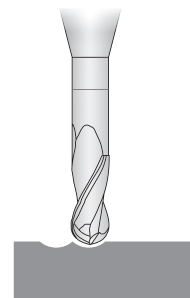

Achtung:
Die angegebenen Schnittparameter sind Richt- und Startwerte.
Kundenspezifische Gegebenheiten wie Antriebsleistung, Maschinenstabilität,
Werkzeugauskragung etc. sind hierbei nicht berücksichtigt.

Attention:
These cutting data are recommendations only.
Customer specific circumstances such as machine power, stability,
tool overhang etc. are not taken into consideration.

AFD 50325

D100-Beschichtung für Graphitbearbeitung

D100 coating for graphite machining

$\varnothing d_1$ [mm]	Z	fz [mm]	n 15000 min1 vf [mm/min.]	n 25000 min1 vf [mm/min.]	n 30000 min1 vf [mm/min.]	n 45000 min1 vf [mm/min.]
0,4	2	0,005	150	250	300	450
0,6	2	0,006	180	300	360	540
1,0	2	0,009	270	450	540	810
1,5	2	0,014	420	700	840	1260
2,0	2	0,019	570	950	1140	1710
4,0	2	0,038	1140	1900	2280	3420

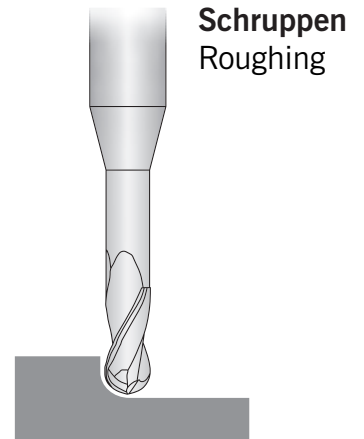

AFD

$\varnothing d_1$ [mm]	Z	fz [mm]	n 15000 min1 vf [mm/min.]	n 25000 min1 vf [mm/min.]	n 30000 min1 vf [mm/min.]	n 45000 min1 vf [mm/min.]
0,4	2	0,004	120	200	240	360
0,6	2	0,004	120	200	240	360
1,0	2	0,007	210	350	420	630
1,5	2	0,011	330	550	660	990
2,0	2	0,015	450	750	900	1350
4,0	2	0,029	870	1450	1750	2610

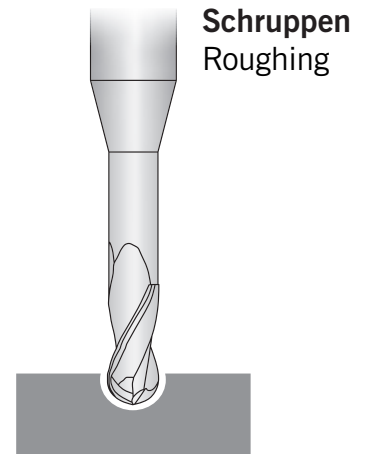
**Achtung:**

Die angegebenen Schnittparameter sind Richt- und Startwerte.
Kundenspezifische Gegebenheiten wie Antriebsleistung, Maschinenstabilität,
Werkzeugauskragung etc. sind hierbei nicht berücksichtigt.

Attention:

These cutting data are recommendations only.
Customer specific circumstances such as machine power, stability,
tool overhang etc. are not taken into consideration.

Alle Angaben in mm / Dimensions in mm

AFD 50325

D100-Beschichtung für Graphitbearbeitung

D100 coating for graphite machining

$\varnothing d_1$ [mm]	Z	fz [mm]	n 15000 min1 vf [mm/min.]	n 25000 min1 vf [mm/min.]	n 30000 min1 vf [mm/min.]	n 45000 min1 vf [mm/min.]
0,4	2	0,005	150	250	300	450
0,6	2	0,006	180	300	360	540
1,0	2	0,011	330	550	660	990
1,5	2	0,016	480	800	960	1440
2,0	2	0,021	630	1050	1260	1890
4,0	2	0,044	1320	2200	2640	3960

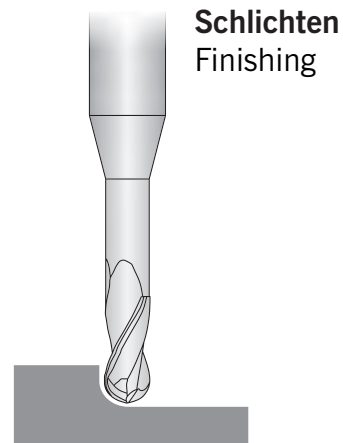

$\varnothing d_1$ [mm]	Z	fz [mm]	n 15000 min1 vf [mm/min.]	n 25000 min1 vf [mm/min.]	n 30000 min1 vf [mm/min.]	n 45000 min1 vf [mm/min.]
0,4	2	0,005	150	250	300	450
0,6	2	0,006	180	300	360	540
1,0	2	0,011	330	550	660	990
1,5	2	0,016	480	800	960	1440
2,0	2	0,021	630	1050	1260	1890
4,0	2	0,044	1320	2200	2640	3960

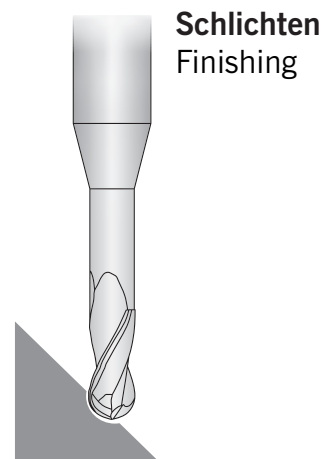

Achtung:
Die angegebenen Schnittparameter sind Richt- und Startwerte.
Kundenspezifische Gegebenheiten wie Antriebsleistung, Maschinenstabilität,
Werkzeugauskragung etc. sind hierbei nicht berücksichtigt.

Attention:
These cutting data are recommendations only.
Customer specific circumstances such as machine power, stability,
tool overhang etc. are not taken into consideration.

Alle Angaben in mm / Dimensions in mm

AFD 51826

D100-Beschichtung für Graphitbearbeitung

D100 coating for graphite machining

$\varnothing d_1$ [mm]	Z	fz [mm]	n 15000 min1 vf [mm/min.]	n 25000 min1 vf [mm/min.]	n 30000 min1 vf [mm/min.]	n 45000 min1 vf [mm/min.]
1,0	2	0,007	210	350	420	630
1,5	2	0,011	330	550	660	990
2,0	2	0,014	420	700	840	1260

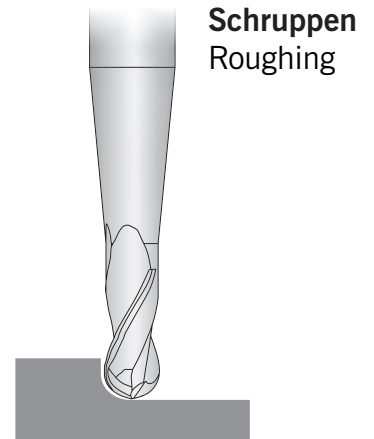

AFD

$\varnothing d_1$ [mm]	Z	fz [mm]	n 15000 min1 vf [mm/min.]	n 25000 min1 vf [mm/min.]	n 30000 min1 vf [mm/min.]	n 45000 min1 vf [mm/min.]
1,0	2	0,008	240	400	480	720
1,5	2	0,012	360	600	720	1080
2,0	2	0,016	480	800	960	1440

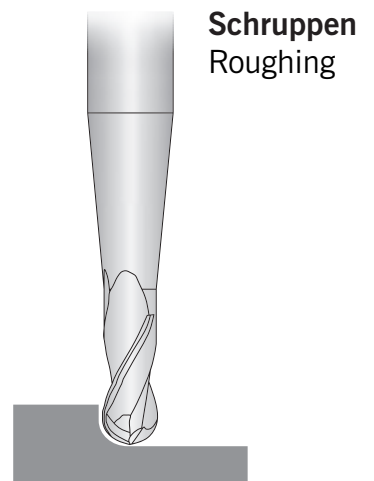
**Achtung:**

Die angegebenen Schnittparameter sind Richt- und Startwerte.
Kundenspezifische Gegebenheiten wie Antriebsleistung, Maschinenstabilität,
Werkzeugauskragung etc. sind hierbei nicht berücksichtigt.

Attention:

These cutting data are recommendations only.
Customer specific circumstances such as machine power, stability,
tool overhang etc. are not taken into consideration.

Alle Angaben in mm / Dimensions in mm

AFD 51826

D100-Beschichtung für Graphitbearbeitung

D100 coating for graphite machining

$\varnothing d_1$ [mm]	Z	fz [mm]	n 15000 min1 vf [mm/min.]	n 25000 min1 vf [mm/min.]	n 30000 min1 vf [mm/min.]	n 45000 min1 vf [mm/min.]
1,0	2	0,008	240	400	480	720
1,5	2	0,012	360	600	720	1080
2,0	2	0,016	480	800	960	1440

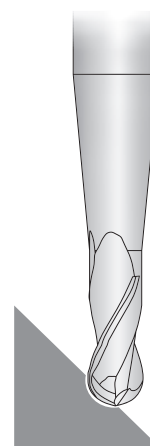
Schlichten
Finishing

AFD

Achtung:
Die angegebenen Schnittparameter sind Richt- und Startwerte.
Kundenspezifische Gegebenheiten wie Antriebsleistung, Maschinenstabilität,
Werkzeugauskragung etc. sind hierbei nicht berücksichtigt.

Attention:
These cutting data are recommendations only.
Customer specific circumstances such as machine power, stability,
tool overhang etc. are not taken into consideration.

AFD 51826

DLC-Beschichtung für Aluminiumlegierungen

DLC coating for aluminium alloys

$\varnothing d_1$ [mm]	Z	Vc m/min.	fz [mm]	n [U/min ¹]	vf [mm/min.]
1,0	2	144	0,020	46000	1840
1,5	2	170	0,025	36000	1800
2,0	2	170	0,030	27000	1650

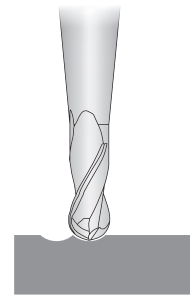

AFD

DLC-Beschichtung für Kupferlegierungen

DLC coating for copper alloys

$\varnothing d_1$ [mm]	Z	Vc m/min.	fz [mm]	n [U/min ¹]	vf [mm/min.]
1,0	2	105	0,020	34000	1360
1,5	2	125	0,025	26000	1300
2,0	2	125	0,300	20000	1200

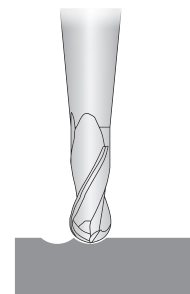
**Achtung:**

Die angegebenen Schnittparameter sind Richt- und Startwerte.
Kundenspezifische Gegebenheiten wie Antriebsleistung, Maschinenstabilität,
Werkzeugauskragung etc. sind hierbei nicht berücksichtigt.

Attention:

These cutting data are recommendations only.
Customer specific circumstances such as machine power, stability,
tool overhang etc. are not taken into consideration.

Alle Angaben in mm / Dimensions in mm

AFD 51821

D100-Beschichtung für Graphitbearbeitung

D100 coating for graphite machining

$\varnothing d_1$ [mm]	Z	fz [mm]	n 10000 min1 vf [mm/min.]	n 15000 min1 vf [mm/min.]	n 20000 min1 vf [mm/min.]	n 30000 min1 vf [mm/min.]
2,0	2	0,019	380	570	760	1140
3,0	2	0,028	560	840	1120	1680
4,0	2	0,038	760	1140	1520	2280
5,0	2	0,047	940	1410	1880	2820
6,0	2	0,056	1120	1680	2240	3360
7,0	2	0,065	1300	1950	2600	3900
8,0	2	0,075	1500	2250	3000	4500
9,0	2	0,084	1680	2520	3360	5040
10,0	2	0,094	1880	2820	3760	5640
12,0	2	0,113	2260	3390	4520	6780

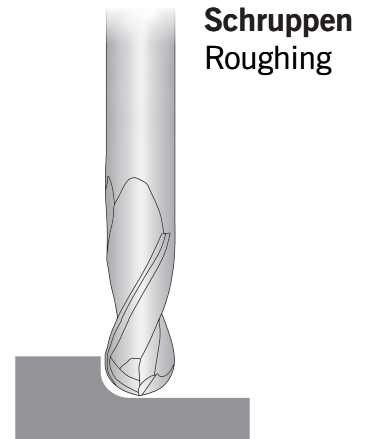

$\varnothing d_1$ [mm]	Z	fz [mm]	n 10000 min1 vf [mm/min.]	n 15000 min1 vf [mm/min.]	n 20000 min1 vf [mm/min.]	n 30000 min1 vf [mm/min.]
2,0	2	0,015	300	450	600	900
3,0	2	0,022	440	660	880	1320
4,0	2	0,029	580	870	1160	1740
5,0	2	0,036	720	1080	1440	2160
6,0	2	0,044	880	1320	1760	2640
7,0	2	0,051	1020	1530	2040	3060
8,0	2	0,058	1160	1740	2320	3480
9,0	2	0,080	1300	1950	2600	3900
10,0	2	0,073	1460	2190	2920	4380
12,0	2	0,087	1740	2610	3480	5220

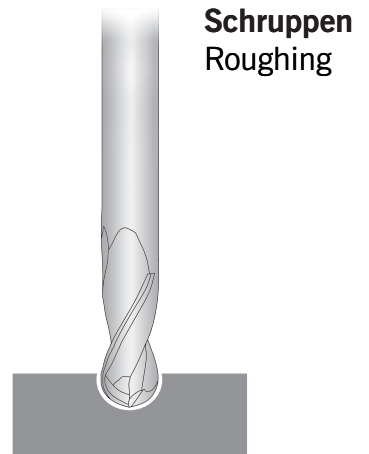

Achtung:
Die angegebenen Schnittparameter sind Richt- und Startwerte.
Kundenspezifische Gegebenheiten wie Antriebsleistung, Maschinenstabilität,
Werkzeugauskragung etc. sind hierbei nicht berücksichtigt.

Attention:
These cutting data are recommendations only.
Customer specific circumstances such as machine power, stability,
tool overhang etc. are not taken into consideration.

Alle Angaben in mm / Dimensions in mm

AFD 51821

D100-Beschichtung für Graphitbearbeitung

D100 coating for graphite machining

$\varnothing d_1$ [mm]	Z	fz [mm]	n 10000 min1 vf [mm/min.]	n 15000 min1 vf [mm/min.]	n 20000 min1 vf [mm/min.]	n 30000 min1 vf [mm/min.]
2,0	2	0,021	420	630	840	1260
3,0	2	0,032	640	960	1280	1920
4,0	2	0,043	860	1290	1720	2580
5,0	2	0,053	1060	1590	2120	3180
6,0	2	0,064	1280	1920	2560	3840
7,0	2	0,074	1480	2220	2960	4440
8,0	2	0,085	1700	2550	3400	5100
9,0	2	0,095	1900	2850	3800	5700
10,0	2	0,107	2140	3210	4280	6420
12,0	2	0,128	2560	3840	5120	7680

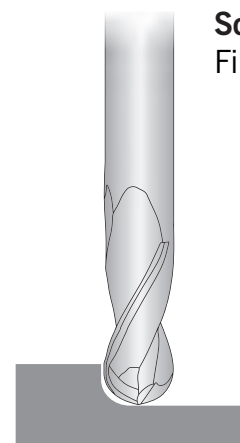
Schlichten
Finishing

AFD

$\varnothing d_1$ [mm]	Z	fz [mm]	n 10000 min1 vf [mm/min.]	n 15000 min1 vf [mm/min.]	n 20000 min1 vf [mm/min.]	n 30000 min1 vf [mm/min.]
2,0	2	0,021	420	630	840	1260
3,0	2	0,032	640	960	1280	1920
4,0	2	0,043	860	1290	1720	2580
5,0	2	0,053	1060	1590	2120	3180
6,0	2	0,064	1280	1920	2560	3840
7,0	2	0,074	1480	2220	2960	4440
8,0	2	0,085	1700	2550	3400	5100
9,0	2	0,095	1900	2850	3800	5700
10,0	2	0,107	2140	3210	4280	6420
12,0	2	0,128	2560	3840	5120	7680

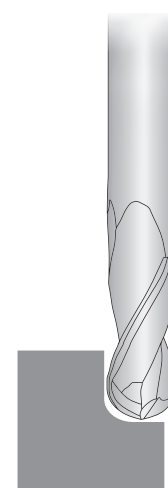
Schlichten
Finishing**Achtung:**

Die angegebenen Schnittparameter sind Richt- und Startwerte.
Kundenspezifische Gegebenheiten wie Antriebsleistung, Maschinenstabilität,
Werkzeugauskragung etc. sind hierbei nicht berücksichtigt.

Attention:

These cutting data are recommendations only.
Customer specific circumstances such as machine power, stability,
tool overhang etc. are not taken into consideration.

Alle Angaben in mm / Dimensions in mm

AFD 51821

DLC-Beschichtung für Aluminiumlegierungen

DLC coating for aluminium alloys

$\varnothing d_1$ [mm]	Z	Vc m/min.	fz [mm]	n [U/min ¹]	vf [mm/min.]
2,0	2	160	0,020	25000	1000
3,0	2	160	0,029	17000	1000
4,0	2	160	0,040	12500	1000
5,0	2	160	0,060	10000	1200
6,0	2	160	0,080	8500	1350
8,0	2	175	0,100	7000	1450
10,0	2	188	0,120	6000	1450
12,0	2	188	0,140	5000	1450

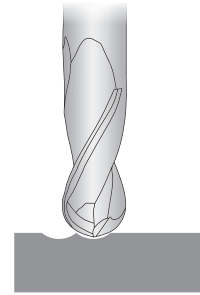

DLC-Beschichtung für Kupferlegierungen

DLC coating for copper alloys

$\varnothing d_1$ [mm]	Z	Vc m/min.	fz [mm]	n [U/min ¹]	vf [mm/min.]
2,0	2	120	0,020	19000	800
3,0	2	115	0,032	12500	800
4,0	2	120	0,042	9500	800
5,0	2	120	0,055	7600	850
6,0	2	120	0,070	6400	900
8,0	2	130	0,090	5100	900
10,0	2	130	0,110	4200	900
12,0	2	130	0,130	3500	900

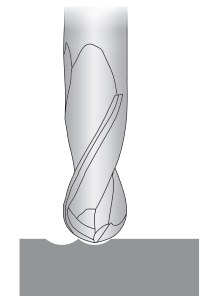

Achtung:
Die angegebenen Schnittparameter sind Richt- und Startwerte.
Kundenspezifische Gegebenheiten wie Antriebsleistung, Maschinenstabilität,
Werkzeugauskragung etc. sind hierbei nicht berücksichtigt.

Attention:
These cutting data are recommendations only.
Customer specific circumstances such as machine power, stability,
tool overhang etc. are not taken into consideration.

Alle Angaben in mm / Dimensions in mm

AFD 51823

D100-Beschichtung für Graphitbearbeitung

D100 coating for graphite machining

$\varnothing d_1$ [mm]	Z	fz [mm]	n 10000 min1 vf [mm/min.]	n 15000 min1 vf [mm/min.]	n 20000 min1 vf [mm/min.]	n 30000 min1 vf [mm/min.]
2,0	2	0,019	380	570	760	1140
3,0	2	0,028	560	840	1120	1680
4,0	2	0,038	760	1140	1520	2280
5,0	2	0,047	940	1410	1880	2820
6,0	2	0,056	1120	1680	2240	3360
7,0	2	0,065	1300	1950	2600	3900
8,0	2	0,075	1500	2250	3000	4500
9,0	2	0,084	1680	2520	3360	5040
10,0	2	0,094	1880	2820	3760	5640
12,0	2	0,113	2260	3390	4520	6780

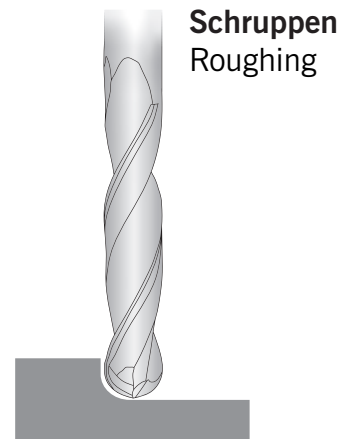

AFD

$\varnothing d_1$ [mm]	Z	fz [mm]	n 10000 min1 vf [mm/min.]	n 15000 min1 vf [mm/min.]	n 20000 min1 vf [mm/min.]	n 30000 min1 vf [mm/min.]
2,0	2	0,015	300	450	600	900
3,0	2	0,022	440	660	880	1320
4,0	2	0,029	580	870	1160	1740
5,0	2	0,036	720	1080	1440	2160
6,0	2	0,044	880	1320	1760	2640
7,0	2	0,051	1020	1530	2040	3060
8,0	2	0,058	1160	1740	2320	3480
9,0	2	0,080	1300	1950	2600	3900
10,0	2	0,073	1460	2190	2920	4380
12,0	2	0,087	1740	2610	3480	5220

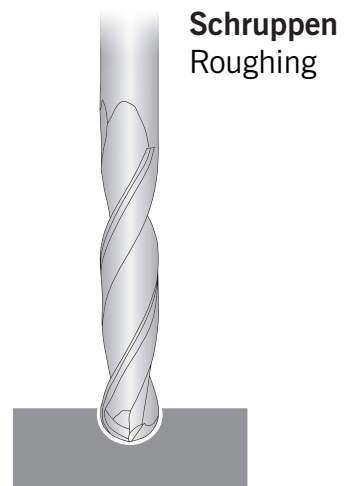
**Achtung:**

Die angegebenen Schnittparameter sind Richt- und Startwerte.
Kundenspezifische Gegebenheiten wie Antriebsleistung, Maschinenstabilität,
Werkzeugauskragung etc. sind hierbei nicht berücksichtigt.

Attention:

These cutting data are recommendations only.
Customer specific circumstances such as machine power, stability,
tool overhang etc. are not taken into consideration.

Alle Angaben in mm / Dimensions in mm

AFD 51823

D100-Beschichtung für Graphitbearbeitung

D100 coating for graphite machining

$\varnothing d_1$ [mm]	Z	fz [mm]	n 10000 min1 vf [mm/min.]	n 15000 min1 vf [mm/min.]	n 20000 min1 vf [mm/min.]	n 30000 min1 vf [mm/min.]
2,0	2	0,021	420	630	840	1260
3,0	2	0,032	640	960	1280	1920
4,0	2	0,043	860	1290	1720	2580
5,0	2	0,053	1060	1590	2120	3180
6,0	2	0,064	1280	1920	2560	3840
7,0	2	0,074	1480	2220	2960	4440
8,0	2	0,085	1700	2550	3400	5100
9,0	2	0,095	1900	2850	3800	5700
10,0	2	0,107	2140	3210	4280	6420
12,0	2	0,128	2560	3840	5120	7680

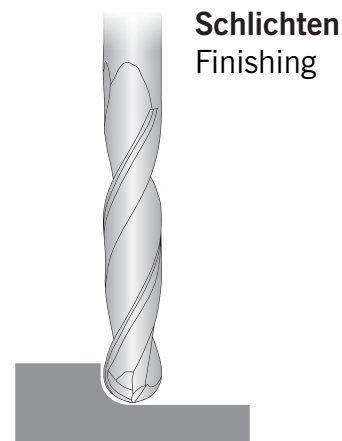

$\varnothing d_1$ [mm]	Z	fz [mm]	n 10000 min1 vf [mm/min.]	n 15000 min1 vf [mm/min.]	n 20000 min1 vf [mm/min.]	n 30000 min1 vf [mm/min.]
2,0	2	0,021	420	630	840	1260
3,0	2	0,032	640	960	1280	1920
4,0	2	0,043	860	1290	1720	2580
5,0	2	0,053	1060	1590	2120	3180
6,0	2	0,064	1280	1920	2560	3840
7,0	2	0,074	1480	2220	2960	4440
8,0	2	0,085	1700	2550	3400	5100
9,0	2	0,095	1900	2850	3800	5700
10,0	2	0,107	2140	3210	4280	6420
12,0	2	0,128	2560	3840	5120	7680

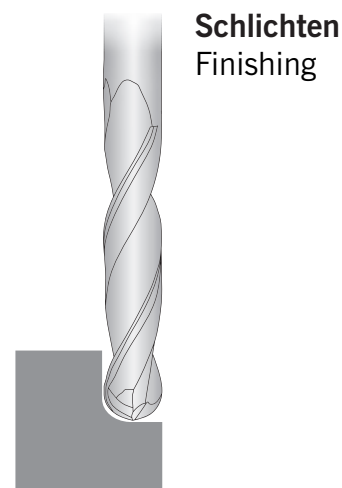

Achtung:
Die angegebenen Schnittparameter sind Richt- und Startwerte.
Kundenspezifische Gegebenheiten wie Antriebsleistung, Maschinenstabilität,
Werkzeugauskragung etc. sind hierbei nicht berücksichtigt.

Attention:
These cutting data are recommendations only.
Customer specific circumstances such as machine power, stability,
tool overhang etc. are not taken into consideration.

Alle Angaben in mm / Dimensions in mm

AFD 51823

DLC-Beschichtung für Aluminiumlegierungen

DLC coating for aluminium alloys

$\varnothing d_1$ [mm]	Z	Vc m/min.	fz [mm]	n [U/min ¹]	vf [mm/min.]
2,0	2	160	0,020	25000	1000
3,0	2	160	0,029	17000	1000
4,0	2	160	0,040	12500	1000
5,0	2	160	0,060	10000	1200
6,0	2	160	0,080	8500	1350
7,0	2	175	0,090	8000	1450
8,0	2	175	0,100	7000	1450
9,0	2	180	0,110	6400	1400
10,0	2	188	0,120	6000	1450
12,0	2	188	0,140	5000	1450

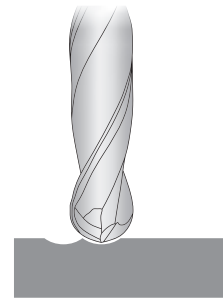

AFD

DLC-Beschichtung für Kupferlegierungen

DLC coating for copper alloys

$\varnothing d_1$ [mm]	Z	Vc m/min.	fz [mm]	n [U/min ¹]	vf [mm/min.]
2,0	2	120	0,020	19000	800
3,0	2	115	0,032	12500	800
4,0	2	120	0,042	9500	800
5,0	2	120	0,055	7600	850
6,0	2	120	0,070	6400	900
7,0	2	125	0,080	5700	900
8,0	2	130	0,090	5100	900
9,0	2	130	0,100	4600	900
10,0	2	130	0,110	4200	900
12,0	2	130	0,130	3500	900

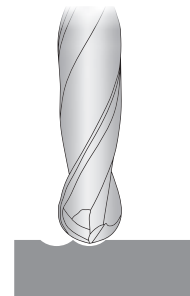
**Achtung:**

Die angegebenen Schnittparameter sind Richt- und Startwerte.
Kundenspezifische Gegebenheiten wie Antriebsleistung, Maschinenstabilität,
Werkzeugauskragung etc. sind hierbei nicht berücksichtigt.

Attention:

These cutting data are recommendations only.
Customer specific circumstances such as machine power, stability,
tool overhang etc. are not taken into consideration.

Alle Angaben in mm / Dimensions in mm

AFD 51820

D100-Beschichtung für Graphitbearbeitung

D100 coating for graphite machining

$\varnothing d_1$ [mm]	Z	fz [mm]	n 10000 min1 vf [mm/min.]	n 15000 min1 vf [mm/min.]	n 20000 min1 vf [mm/min.]	n 30000 min1 vf [mm/min.]
2,0	2	0,018	360	540	720	1080
2,5	2	0,023	460	690	920	1380
3,0	2	0,028	560	840	1120	1680
3,5	2	0,033	660	990	1320	1980
4,0	2	0,038	760	1140	1520	2280
5,0	2	0,047	940	1410	1880	2820
6,0	2	0,056	1120	1680	2240	3360
8,0	2	0,075	1500	2250	3000	4500
10,0	2	0,094	1880	2820	3760	5640
12,0	2	0,113	2260	3390	4520	6780

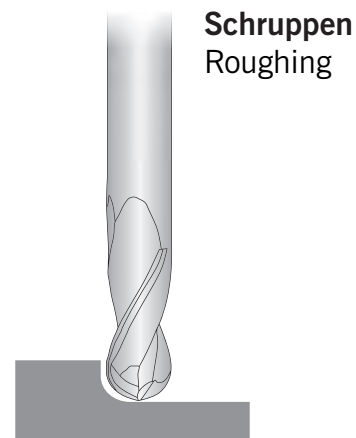

$\varnothing d_1$ [mm]	Z	fz [mm]	n 10000 min1 vf [mm/min.]	n 15000 min1 vf [mm/min.]	n 20000 min1 vf [mm/min.]	n 30000 min1 vf [mm/min.]
2,0	2	0,015	300	450	600	900
2,5	2	0,018	360	540	720	1080
3,0	2	0,022	440	660	880	1320
3,5	2	0,026	520	780	1040	1560
4,0	2	0,029	580	870	1160	1740
5,0	2	0,036	720	1080	1440	2160
6,0	2	0,044	880	1320	1760	2640
8,0	2	0,058	1160	1740	2320	3480
10,0	2	0,073	1460	2190	2920	4380
12,0	2	0,087	1740	2610	3480	5220

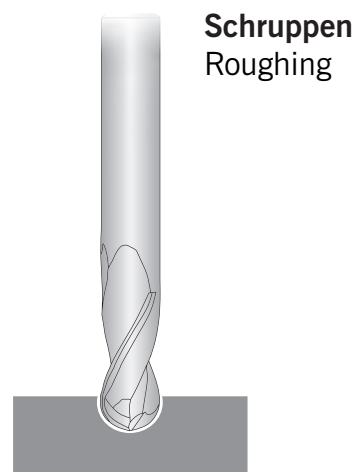

Achtung:
Die angegebenen Schnittparameter sind Richt- und Startwerte.
Kundenspezifische Gegebenheiten wie Antriebsleistung, Maschinenstabilität,
Werkzeugauskragung etc. sind hierbei nicht berücksichtigt.

Attention:
These cutting data are recommendations only.
Customer specific circumstances such as machine power, stability,
tool overhang etc. are not taken into consideration.

Alle Angaben in mm / Dimensions in mm

AFD 51820

D100-Beschichtung für Graphitbearbeitung

D100 coating for graphite machining

$\varnothing d_1$ [mm]	Z	fz [mm]	n 10000 min1 vf [mm/min.]	n 15000 min1 vf [mm/min.]	n 20000 min1 vf [mm/min.]	n 30000 min1 vf [mm/min.]
2,0	2	0,022	440	660	880	1320
2,5	2	0,027	540	810	1080	1620
3,0	2	0,032	640	960	1280	1920
3,5	2	0,037	740	1110	1480	2220
4,0	2	0,043	860	1290	1720	2580
5,0	2	0,053	1060	1590	2120	3180
6,0	2	0,064	1280	1920	2560	3840
8,0	2	0,085	1700	2550	3400	5100
10,0	2	0,107	2140	3210	4280	6420
12,0	2	0,128	2560	3840	5120	7680

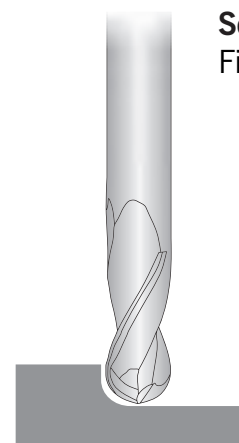
Schlichten
Finishing

AFD

$\varnothing d_1$ [mm]	Z	fz [mm]	n 10000 min1 vf [mm/min.]	n 15000 min1 vf [mm/min.]	n 20000 min1 vf [mm/min.]	n 30000 min1 vf [mm/min.]
2,0	2	0,022	440	660	880	1320
2,5	2	0,027	540	810	1080	1620
3,0	2	0,032	640	960	1280	1920
3,5	2	0,037	740	1110	1480	2220
4,0	2	0,043	860	1290	1720	2580
5,0	2	0,053	1060	1590	2120	3180
6,0	2	0,064	1280	1920	2560	3840
8,0	2	0,085	1700	2550	3400	5100
10,0	2	0,107	2140	3210	4280	6420
12,0	2	0,128	2560	3840	5120	7680

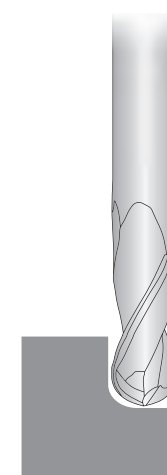
Schlichten
Finishing**Achtung:**

Die angegebenen Schnittparameter sind Richt- und Startwerte.
Kundenspezifische Gegebenheiten wie Antriebsleistung, Maschinenstabilität,
Werkzeugauskragung etc. sind hierbei nicht berücksichtigt.

Attention:

These cutting data are recommendations only.
Customer specific circumstances such as machine power, stability,
tool overhang etc. are not taken into consideration.

Alle Angaben in mm / Dimensions in mm

AFD 51820

DLC-Beschichtung für Aluminiumlegierungen

DLC coating for aluminium alloys

$\varnothing d_1$ [mm]	Z	Vc m/min.	fz [mm]	n [U/min ¹]	vf [mm/min.]
2,0	2	160	0,020	25000	1000
3,0	2	160	0,029	17000	1000
4,0	2	160	0,040	12500	1000
5,0	2	160	0,060	10000	1200
6,0	2	160	0,080	8500	1350
8,0	2	175	0,100	7000	1450
10,0	2	188	0,120	6000	1450
12,0	2	188	0,140	5000	1450

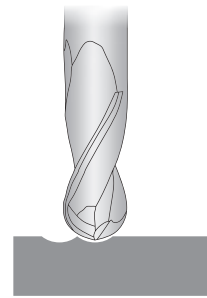

DLC-Beschichtung für Kupferlegierungen

DLC coating for copper alloys

$\varnothing d_1$ [mm]	Z	Vc m/min.	fz [mm]	n [U/min ¹]	vf [mm/min.]
2,0	2	120	0,020	19000	800
3,0	2	115	0,032	12500	800
4,0	2	120	0,042	9500	800
5,0	2	120	0,055	7600	850
6,0	2	120	0,070	6400	900
8,0	2	130	0,090	5100	900
10,0	2	130	0,110	4200	900
12,0	2	130	0,130	3500	900

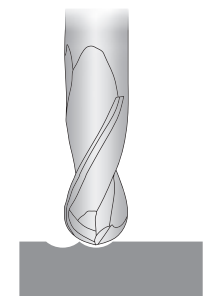

Achtung:
Die angegebenen Schnittparameter sind Richt- und Startwerte.
Kundenspezifische Gegebenheiten wie Antriebsleistung, Maschinenstabilität,
Werkzeugauskragung etc. sind hierbei nicht berücksichtigt.

Attention:
These cutting data are recommendations only.
Customer specific circumstances such as machine power, stability,
tool overhang etc. are not taken into consideration.

Alle Angaben in mm / Dimensions in mm

AFD 54030

D100-Beschichtung für Graphitbearbeitung

D100 coating for graphite machining

$\varnothing d_1$ [mm]	Z	fz [mm]	n 10000 min1 vf [mm/min.]	n 15000 min1 vf [mm/min.]	n 20000 min1 vf [mm/min.]	n 30000 min1 vf [mm/min.]
2,0	3	0,024	720	1080	1440	2160
3,0	3	0,035	1050	1575	2100	3150
4,0	3	0,047	1410	2115	2820	4230
5,0	3	0,059	1770	2655	3540	5310
6,0	3	0,071	2130	3195	4260	6390
8,0	3	0,094	2820	4230	5640	8460
10,0	3	0,118	3540	5310	7080	10620
12,0	3	0,141	4230	6345	8460	12690

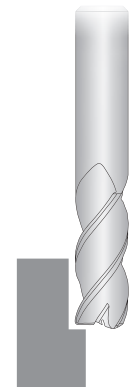

Schruppen
Roughing

AFD

$\varnothing d_1$ [mm]	Z	fz [mm]	n 10000 min1 vf [mm/min.]	n 15000 min1 vf [mm/min.]	n 20000 min1 vf [mm/min.]	n 30000 min1 vf [mm/min.]
2,0	3	0,018	540	810	1080	1620
3,0	3	0,027	810	1215	1620	2430
4,0	3	0,036	1080	1620	2160	3240
5,0	3	0,045	1350	2025	2700	4050
6,0	3	0,055	1650	2475	3300	4950
8,0	3	0,073	2190	3285	4380	6570
10,0	3	0,091	2730	4095	5460	8190
12,0	3	0,109	3270	4905	6540	9810

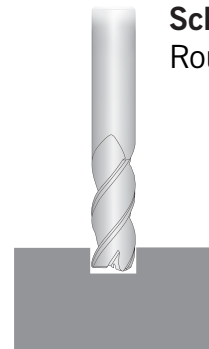

Schruppen
Roughing

Achtung:

Die angegebenen Schnittparameter sind Richt- und Startwerte.
Kundenspezifische Gegebenheiten wie Antriebsleistung, Maschinenstabilität,
Werkzeugauskragung etc. sind hierbei nicht berücksichtigt.

Attention:

These cutting data are recommendations only.
Customer specific circumstances such as machine power, stability,
tool overhang etc. are not taken into consideration.

Alle Angaben in mm / Dimensions in mm

AFD 54030

D100-Beschichtung für Graphitbearbeitung

D100 coating for graphite machining

$\varnothing d_1$ [mm]	Z	fz [mm]	n 10000 min1 vf [mm/min.]	n 15000 min1 vf [mm/min.]	n 20000 min1 vf [mm/min.]	n 30000 min1 vf [mm/min.]
2,0	3	0,027	810	1215	1620	2430
3,0	3	0,040	1200	1800	2400	3600
4,0	3	0,053	1590	2385	3180	4770
5,0	3	0,067	2010	3015	4020	6030
6,0	3	0,080	2400	3600	4800	7200
8,0	3	0,107	3210	4815	6420	9630
10,0	3	0,133	3990	5985	7980	11970
12,0	3	0,160	4800	7200	9600	14400

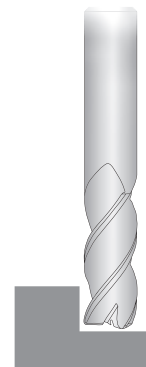
Schlichten
Finishing

$\varnothing d_1$ [mm]	Z	fz [mm]	n 10000 min1 vf [mm/min.]	n 15000 min1 vf [mm/min.]	n 20000 min1 vf [mm/min.]	n 30000 min1 vf [mm/min.]
2,0	3	0,027	810	1215	1620	2430
3,0	3	0,040	1200	1800	2400	3600
4,0	3	0,053	1590	2385	3180	4770
5,0	3	0,067	2010	3015	4020	6030
6,0	3	0,080	2400	3600	4800	7200
8,0	3	0,107	3210	4815	6420	9630
10,0	3	0,133	3990	5985	7980	11970
12,0	3	0,160	4800	7200	9600	14400

Schlichten
Finishing

Achtung:
Die angegebenen Schnittparameter sind Richt- und Startwerte.
Kundenspezifische Gegebenheiten wie Antriebsleistung, Maschinenstabilität,
Werkzeugauskragung etc. sind hierbei nicht berücksichtigt.

Attention:
These cutting data are recommendations only.
Customer specific circumstances such as machine power, stability,
tool overhang etc. are not taken into consideration.

AFD 54030

DLC-Beschichtung für Aluminiumlegierungen

DLC coating for aluminium alloys

$\varnothing d_1$ [mm]	Z	Vc m/min.	fz [mm]	n [U/min ¹]	vf [mm/min.]
2,0	3	170	0,012	27000	1000
3,0	3	200	0,017	21000	1100
4,0	3	190	0,026	15000	1200
5,0	3	190	0,034	12000	1250
6,0	3	190	0,046	10000	1400
8,0	3	190	0,066	7500	1500
10,0	3	190	0,094	6000	1700
12,0	3	190	0,110	5000	1700

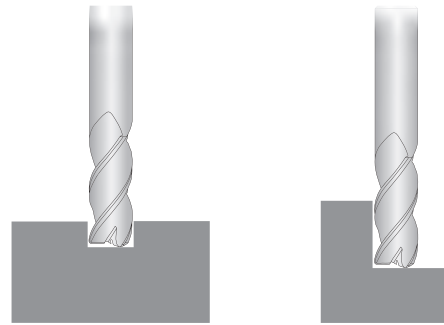

AFD

DLC-Beschichtung für Kupferlegierungen

DLC coating for copper alloys

$\varnothing d_1$ [mm]	Z	Vc m/min.	fz [mm]	n [U/min ¹]	vf [mm/min.]
2,0	3	65	0,008	10000	240
3,0	3	75	0,013	8000	320
4,0	3	75	0,020	6000	360
5,0	3	75	0,026	4800	385
6,0	3	75	0,033	4000	400
8,0	3	75	0,050	3000	460
10,0	3	75	0,066	2400	480
12,0	3	75	0,080	2000	510

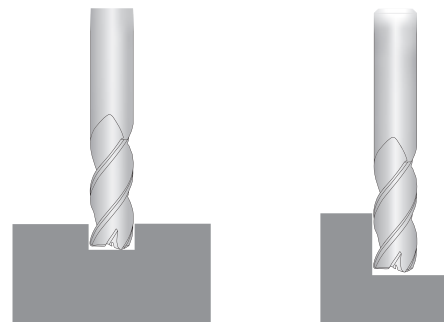
**Achtung:**

Die angegebenen Schnittparameter sind Richt- und Startwerte.
Kundenspezifische Gegebenheiten wie Antriebsleistung, Maschinenstabilität,
Werkzeugauskragung etc. sind hierbei nicht berücksichtigt.

Attention:

These cutting data are recommendations only.
Customer specific circumstances such as machine power, stability,
tool overhang etc. are not taken into consideration.

Alle Angaben in mm / Dimensions in mm

AFD 54031

D100-Beschichtung für Graphitbearbeitung

D100 coating for graphite machining

$\varnothing d_1$ [mm]	Z	fz [mm]	n 10000 min1 vf [mm/min.]	n 15000 min1 vf [mm/min.]	n 20000 min1 vf [mm/min.]	n 30000 min1 vf [mm/min.]
2,0	3	0,019	570	855	1140	1710
3,0	3	0,028	840	1260	1680	2520
4,0	3	0,038	1140	1710	2280	3420
5,0	3	0,047	1410	2115	2820	4230
6,0	3	0,056	1680	2520	3360	5040
8,0	3	0,075	2250	3375	4500	6750
10,0	3	0,094	2820	4230	5640	8460
12,0	3	0,113	3390	5085	6780	10170

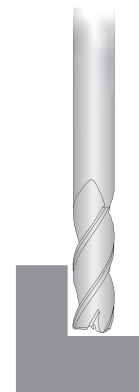

Schruppen
Roughing

$\varnothing d_1$ [mm]	Z	fz [mm]	n 10000 min1 vf [mm/min.]	n 15000 min1 vf [mm/min.]	n 20000 min1 vf [mm/min.]	n 30000 min1 vf [mm/min.]
2,0	3	0,021	630	945	1260	1890
3,0	3	0,032	960	1140	1920	2880
4,0	3	0,043	1290	1935	2580	3870
5,0	3	0,053	1590	2385	3180	4770
6,0	3	0,064	1920	2880	3840	5760
8,0	3	0,085	2550	3825	5100	7650
10,0	3	0,107	3210	4815	6420	9630
12,0	3	0,128	3840	5760	7680	11520

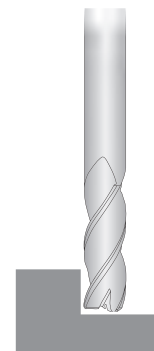

Schlichten
Finishing

Achtung:
Die angegebenen Schnittparameter sind Richt- und Startwerte.
Kundenspezifische Gegebenheiten wie Antriebsleistung, Maschinenstabilität,
Werkzeugauskragung etc. sind hierbei nicht berücksichtigt.

Attention:
These cutting data are recommendations only.
Customer specific circumstances such as machine power, stability,
tool overhang etc. are not taken into consideration.

Alle Angaben in mm / Dimensions in mm

AFD 54031

D100-Beschichtung für Graphitbearbeitung

D100 coating for graphite machining

$\varnothing d_1$ [mm]	Z	fz [mm]	n 10000 min1 vf [mm/min.]	n 15000 min1 vf [mm/min.]	n 20000 min1 vf [mm/min.]	n 30000 min1 vf [mm/min.]
2,0	3	0,021	630	945	1260	1890
3,0	3	0,032	960	1440	1920	2880
4,0	3	0,043	1290	1935	2580	3870
5,0	3	0,053	1590	2385	3180	4770
6,0	3	0,064	1920	2880	3840	5760
8,0	3	0,085	2550	3825	5100	7650
10,0	3	0,107	3210	4815	6420	9630
12,0	3	0,128	3840	5760	7680	11520

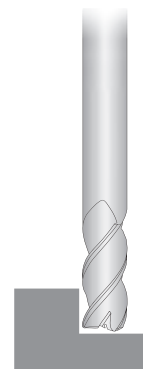
Schlichten
Finishing

AFD

Achtung:

Die angegebenen Schnittparameter sind Richt- und Startwerte.
Kundenspezifische Gegebenheiten wie Antriebsleistung, Maschinenstabilität,
Werkzeugauskragung etc. sind hierbei nicht berücksichtigt.

Attention:

These cutting data are recommendations only.
Customer specific circumstances such as machine power, stability,
tool overhang etc. are not taken into consideration.

Alle Angaben in mm / Dimensions in mm

AFD 54031

DLC-Beschichtung für Aluminiumlegierungen

DLC coating for aluminium alloys

$\varnothing d_1$ [mm]	Z	Vc m/min.	fz [mm]	n [U/min ¹]	vf [mm/min.]
2,0	3	170	0,012	27000	1000
3,0	3	200	0,017	21000	1100
4,0	3	190	0,026	15000	1200
5,0	3	190	0,034	12000	1250
6,0	3	190	0,046	10000	1400
8,0	3	190	0,066	7500	1500
10,0	3	190	0,094	6000	1700
12,0	3	190	0,110	5000	1700

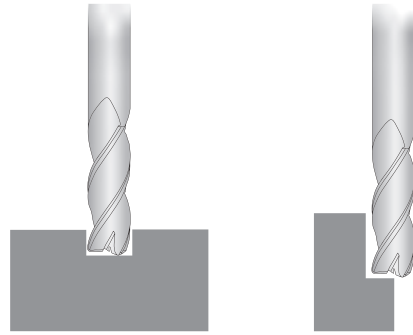

DLC-Beschichtung für Kupferlegierungen

DLC coating for copper alloys

$\varnothing d_1$ [mm]	Z	Vc m/min.	fz [mm]	n [U/min ¹]	vf [mm/min.]
2,0	3	65	0,008	10000	240
3,0	3	75	0,013	8000	320
4,0	3	75	0,020	6000	360
5,0	3	75	0,026	4800	385
6,0	3	75	0,033	4000	400
8,0	3	75	0,050	3000	460
10,0	3	75	0,066	2400	480
12,0	3	75	0,080	2000	510

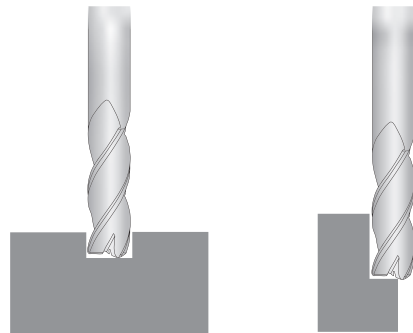

Achtung:
Die angegebenen Schnittparameter sind Richt- und Startwerte.
Kundenspezifische Gegebenheiten wie Antriebsleistung, Maschinenstabilität,
Werkzeugauskragung etc. sind hierbei nicht berücksichtigt.

Attention:
These cutting data are recommendations only.
Customer specific circumstances such as machine power, stability,
tool overhang etc. are not taken into consideration.

AFD 51830

D100-Beschichtung für Graphitbearbeitung

D100 coating for graphite machining

$\varnothing d_1$ [mm]	Z	fz [mm]	n 10000 min1 vf [mm/min.]	n 15000 min1 vf [mm/min.]	n 20000 min1 vf [mm/min.]	n 30000 min1 vf [mm/min.]
2,0	3	0,018	540	810	1080	1620
2,5	3	0,023	690	1035	1380	2070
3,0	3	0,028	840	1260	1680	2520
3,5	3	0,033	990	1485	1980	2970
4,0	3	0,038	1140	1710	2280	3420
5,0	3	0,047	1410	2115	2820	4230
6,0	3	0,056	1680	2520	3360	5040
8,0	3	0,075	2250	3375	4500	6750
10,0	3	0,094	2820	4230	5640	8460
12,0	3	0,113	3390	5085	6780	10170

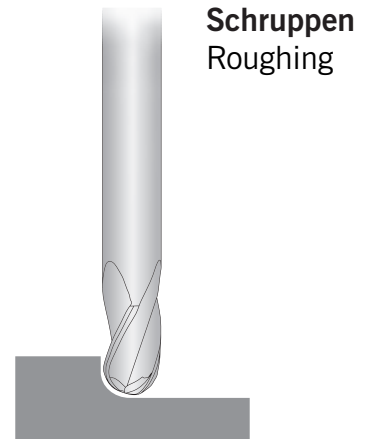

AFD

$\varnothing d_1$ [mm]	Z	fz [mm]	n 10000 min1 vf [mm/min.]	n 15000 min1 vf [mm/min.]	n 20000 min1 vf [mm/min.]	n 30000 min1 vf [mm/min.]
2,0	3	0,015	450	675	900	1350
2,5	3	0,018	540	810	1080	1620
3,0	3	0,022	660	990	1320	1980
3,5	3	0,026	780	1170	1560	2340
4,0	3	0,029	870	1305	1740	2610
5,0	3	0,036	1080	1620	2160	3240
6,0	3	0,044	1320	1980	2640	3960
8,0	3	0,058	1740	2610	3480	5220
10,0	3	0,073	2190	3285	4380	6570
12,0	3	0,087	2610	3915	5220	7830

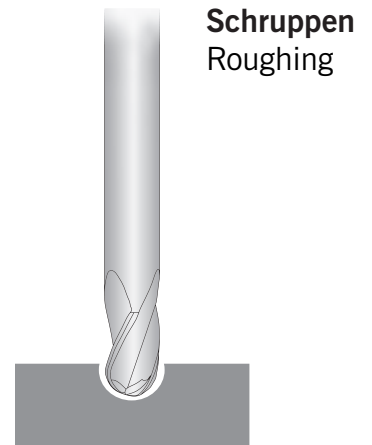
**Achtung:**

Die angegebenen Schnittparameter sind Richt- und Startwerte.
Kundenspezifische Gegebenheiten wie Antriebsleistung, Maschinenstabilität,
Werkzeugauskragung etc. sind hierbei nicht berücksichtigt.

Attention:

These cutting data are recommendations only.
Customer specific circumstances such as machine power, stability,
tool overhang etc. are not taken into consideration.

Alle Angaben in mm / Dimensions in mm

AFD 51830

D100-Beschichtung für Graphitbearbeitung

D100 coating for graphite machining

$\varnothing d_1$ [mm]	Z	fz [mm]	n 10000 min1 vf [mm/min.]	n 15000 min1 vf [mm/min.]	n 20000 min1 vf [mm/min.]	n 30000 min1 vf [mm/min.]
2,0	3	0,022	660	990	1320	1980
2,5	3	0,027	810	1215	1620	2430
3,0	3	0,032	960	1440	1920	2880
3,5	3	0,037	1110	1665	2220	3330
4,0	3	0,043	1290	1935	2580	3870
5,0	3	0,053	1590	2385	3180	4770
6,0	3	0,064	1920	2880	3840	5760
8,0	3	0,085	2550	3825	5100	7650
10,0	3	0,107	3210	4815	6420	9630
12,0	3	0,128	3840	5760	7680	11520

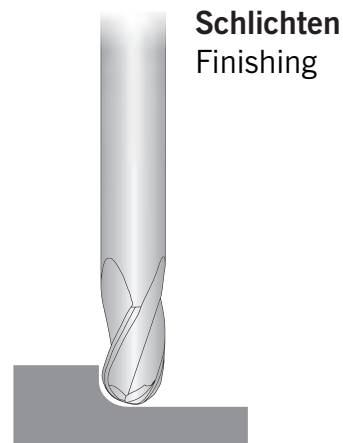

$\varnothing d_1$ [mm]	Z	fz [mm]	n 10000 min1 vf [mm/min.]	n 15000 min1 vf [mm/min.]	n 20000 min1 vf [mm/min.]	n 30000 min1 vf [mm/min.]
2,0	3	0,022	660	990	1320	1980
2,5	3	0,027	810	1215	1620	2430
3,0	3	0,032	960	1440	1920	2880
3,5	3	0,037	1110	1665	2220	3330
4,0	3	0,043	1290	1935	2580	3870
5,0	3	0,053	1590	2385	3180	4770
6,0	3	0,064	1920	2880	3840	5760
8,0	3	0,085	2550	3825	5100	7650
10,0	3	0,107	3210	4815	6420	9630
12,0	3	0,128	3840	5760	7680	11520

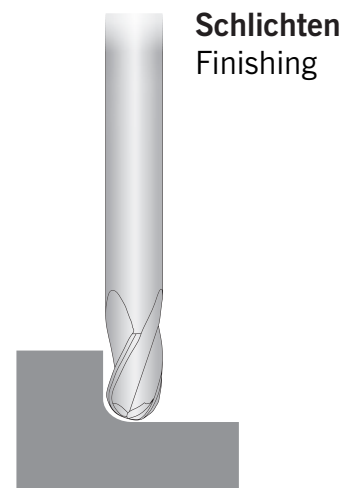

Achtung:
Die angegebenen Schnittparameter sind Richt- und Startwerte.
Kundenspezifische Gegebenheiten wie Antriebsleistung, Maschinenstabilität,
Werkzeugauskragung etc. sind hierbei nicht berücksichtigt.

Attention:
These cutting data are recommendations only.
Customer specific circumstances such as machine power, stability,
tool overhang etc. are not taken into consideration.

Alle Angaben in mm / Dimensions in mm

AFD 51830

DLC-Beschichtung für Aluminiumlegierungen

DLC coating for aluminium alloys

$\varnothing d_1$ [mm]	Z	Vc m/min.	fz [mm]	n [U/min ¹]	vf [mm/min.]
2,0	3	160	0,020	25000	1000
3,0	3	160	0,029	17000	1000
4,0	3	160	0,040	12500	1000
5,0	3	160	0,060	10000	1200
6,0	3	160	0,080	8500	1350
7,0	3	175	0,090	8000	1450
8,0	3	175	0,100	7000	1450
9,0	3	180	0,110	6400	1400
10,0	3	188	0,120	6000	1450
12,0	3	188	0,140	5000	1450

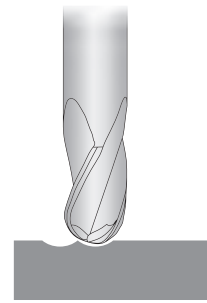

AFD

DLC-Beschichtung für Kupferlegierungen

DLC coating for copper alloys

$\varnothing d_1$ [mm]	Z	Vc m/min.	fz [mm]	n [U/min ¹]	vf [mm/min.]
2,0	3	120	0,020	19000	800
3,0	3	115	0,032	12500	800
4,0	3	120	0,042	9500	800
5,0	3	120	0,055	7600	850
6,0	3	120	0,070	6400	900
7,0	3	125	0,080	5700	900
8,0	3	130	0,090	5100	900
9,0	3	130	0,100	4600	900
10,0	3	130	0,110	4200	900
12,0	3	130	0,130	3500	900

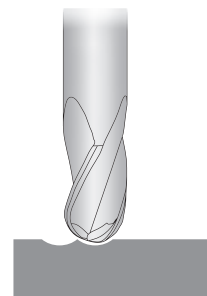
**Achtung:**

Die angegebenen Schnittparameter sind Richt- und Startwerte.
Kundenspezifische Gegebenheiten wie Antriebsleistung, Maschinenstabilität,
Werkzeugauskragung etc. sind hierbei nicht berücksichtigt.

Attention:

These cutting data are recommendations only.
Customer specific circumstances such as machine power, stability,
tool overhang etc. are not taken into consideration.

Alle Angaben in mm / Dimensions in mm

AFD 50740

D100-Beschichtung für Graphitbearbeitung

D100 coating for graphite machining

$\varnothing d_1$ [mm]	Z	fz [mm]	n 10000 min1 vf [mm/min.]	n 15000 min1 vf [mm/min.]	n 20000 min1 vf [mm/min.]	n 30000 min1 vf [mm/min.]
6,0	4	0,056	2240	3360	4460	6720
8,0	4	0,075	3000	4500	6000	9000
10,0	4	0,094	3760	5640	7520	11280
12,0	4	0,113	4520	6780	9040	13560

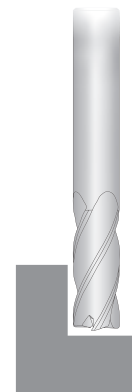

Schruppen
Roughing

$\varnothing d_1$ [mm]	Z	fz [mm]	n 10000 min1 vf [mm/min.]	n 15000 min1 vf [mm/min.]	n 20000 min1 vf [mm/min.]	n 30000 min1 vf [mm/min.]
6,0	4	0,044	1760	2640	3520	5280
8,0	4	0,058	2320	3480	4640	6960
10,0	4	0,073	2920	4380	5840	8760
12,0	4	0,087	3480	5220	6960	10440



Schruppen
Roughing

Achtung:
Die angegebenen Schnittparameter sind Richt- und Startwerte.
Kundenspezifische Gegebenheiten wie Antriebsleistung, Maschinenstabilität,
Werkzeugauskragung etc. sind hierbei nicht berücksichtigt.

Attention:
These cutting data are recommendations only.
Customer specific circumstances such as machine power, stability,
tool overhang etc. are not taken into consideration.

Alle Angaben in mm / Dimensions in mm

AFD 50740

D100-Beschichtung für Graphitbearbeitung

D100 coating for graphite machining

$\varnothing d_1$ [mm]	Z	fz [mm]	n 10000 min1 vf [mm/min.]	n 15000 min1 vf [mm/min.]	n 20000 min1 vf [mm/min.]	n 30000 min1 vf [mm/min.]
6,0	4	0,080	3200	4800	6400	9600
8,0	4	0,107	4280	6420	8560	12840
10,0	4	0,133	5320	7980	10640	15960
12,0	4	0,160	6400	9600	12800	19200

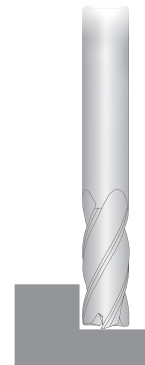
Schlichten
Finishing

AFD

$\varnothing d_1$ [mm]	Z	fz [mm]	n 10000 min1 vf [mm/min.]	n 15000 min1 vf [mm/min.]	n 20000 min1 vf [mm/min.]	n 30000 min1 vf [mm/min.]
6,0	4	0,080	3200	4800	6400	9600
8,0	4	0,107	4280	6420	8560	12840
10,0	4	0,133	5320	7980	10640	15960
12,0	4	0,160	6400	9600	12800	19200

Schlichten
Finishing**Achtung:**

Die angegebenen Schnittparameter sind Richt- und Startwerte.
Kundenspezifische Gegebenheiten wie Antriebsleistung, Maschinenstabilität,
Werkzeugauskragung etc. sind hierbei nicht berücksichtigt.

Attention:

These cutting data are recommendations only.
Customer specific circumstances such as machine power, stability,
tool overhang etc. are not taken into consideration.

Alle Angaben in mm / Dimensions in mm

AFD 50740

DLC-Beschichtung für Aluminiumlegierungen

DLC coating for aluminium alloys

$\varnothing d_1$ [mm]	Z	Vc m/min.	fz [mm]	n [U/min ¹]	vf [mm/min.]
6,0	4	190	0,046	10000	1850
8,0	4	190	0,066	7500	2000
10,0	4	190	0,093	6000	2250
12,0	4	190	0,112	5000	2250

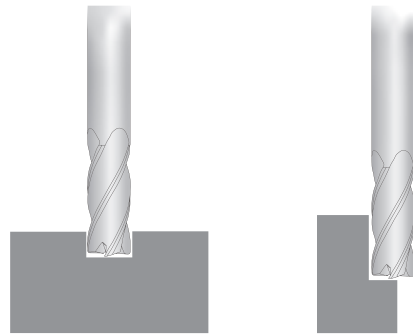

DLC-Beschichtung für Kupferlegierungen

DLC coating for copper alloys

$\varnothing d_1$ [mm]	Z	Vc m/min.	fz [mm]	n [U/min ¹]	vf [mm/min.]
6,0	4	75	0,033	4000	530
8,0	4	75	0,050	3000	600
10,0	4	75	0,066	2400	640
12,0	4	75	0,085	2000	680

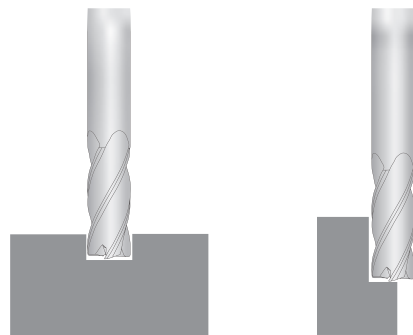

Achtung:
Die angegebenen Schnittparameter sind Richt- und Startwerte.
Kundenspezifische Gegebenheiten wie Antriebsleistung, Maschinenstabilität,
Werkzeugauskragung etc. sind hierbei nicht berücksichtigt.

Attention:
These cutting data are recommendations only.
Customer specific circumstances such as machine power, stability,
tool overhang etc. are not taken into consideration.